



Construction

High-density polyethylene tank, resistant to corrosion, with minimum overall dimensions.

- **GEO 40** single tank with 40 liter nominal capacity for the installation of a GXR type.
- **GEO 230** single tank with 230 liter nominal capacity for the installation of an electropump type GM 10, GQ, GX or GM series.
- **GEO 500** double tank with 500 liter nominal capacity for the installation of two electropumps type GM 10, GQ, GX or GM series.

Pipe kit for electropump connection.
Two possible installation, at ground level or underground.
For underground installation, extensions can be used.
Easy pump access through a cover fixed with screws.

Applications

Automatic waste water collecting and lifting stations, to handle domestic, civil and industrial waste water.
For collecting and lifting clean waste water and rain water.
For flood drainage.

Designation

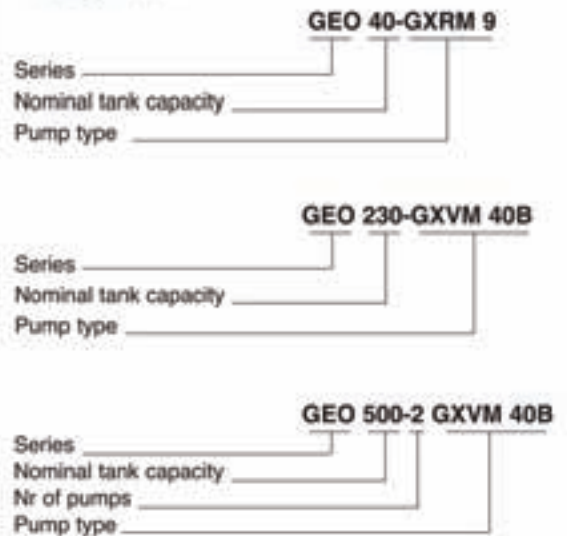

Installation examples



Pumps characteristics

GEO 40-GXRM

GEO 40-GXRM GF



Features

Automatic collecting and lifting station for clean water with GXRM pump type.

It includes:

- 1 40 l capacity tank
- 1 single-phase pump with 5 m cable and float switch
- 1 non-return valve with clapet on the pump delivery side
- 1 discharge pipe kit arranged for the connection of a Ø 40 mm PVC pipe
- 1 PVC adapting nipple for Ø 40 mm inlet
- 1 connector for Ø 25 mm flexible pipe

ON DEMAND

- 1 pump with 10 m cable

Single-phase type	1 ~ 230 V		Q max m ³ /h	H max m
	kW	A		
GEO 40-GXRM 9	0,25	2,5	10,2	8,3
GEO 40-GXRM 9 GF	0,25	2,5	10,2	8,3
GEO 40-GXRM 11 GF	0,37	3,5	12	10,4
GEO 40-GXRM 13 GF	0,45	4,5	13,2	11,7



GXRM

Submersible drainage pump in chrome-nickel stainless steel, for clean water containing solids up to 10 mm grain size, with vertical delivery port.

Open impeller.

2-pole induction motor, 50Hz (n = 2900 rpm),

Single-phase 230 V +/-10% with float switch and thermal protector.

- GXRM: with standard float switch.

- GXRM .. GF: with vertical magnetic float switch.

Incorporated capacitor.

Cable length 5 m, Shuko plug.

Liquid temperature up to 50 °C

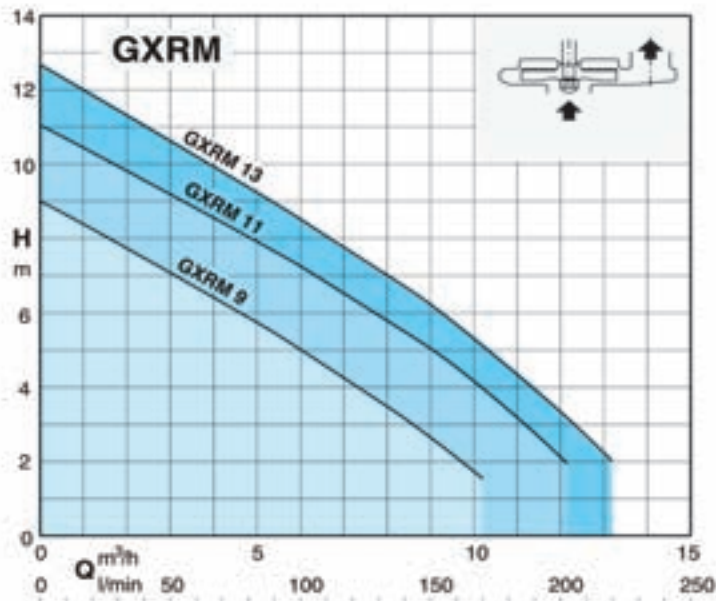

Pumps characteristics

GEO 230-GM 10



Features

Automatic clear water collecting and lifting station GM 10 pump series.

include:

- 1 tank capacity 230 lt
- 1 single-phase pump with 5 m cable and float switch
- 1 control box QM 6,3 type with capacitor
- 1 discharge pipe kit Ø 40 mm in PVC

ON DEMAND

- 1 pump with 10 m cable
- 1 discharge pipe kit Ø 40 mm in PVC with a ball valve and non-return ball valve
- 1 support kit with safety float switch and auto-supplied control panel for remote alarm with horn and flashing light - extension 300 mm

Single-phase type	1 ~ 230 V		Q max m ³ /h	H max m
	kW	A		
GEO 230-GM 10	0,3	1,75	12	6,5

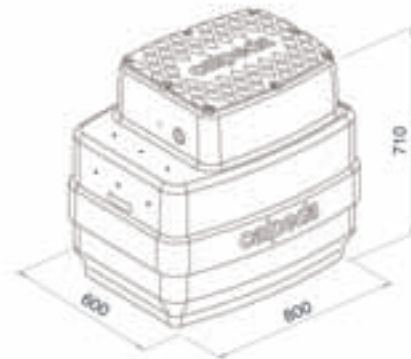

GM 10

Submersible drainage pump constructed from composite polymers.
 Shaft of chrome steel AISI 430.
 2-pole induction motor, 50Hz (n = 2900 rpm).
 Single-phase 230 V +/-10% with thermal protector.
 Float switch for automatic operation.
 5 m cable and control box QM 6,3 with capacitor.
 Liquid temperature up to 35 °C

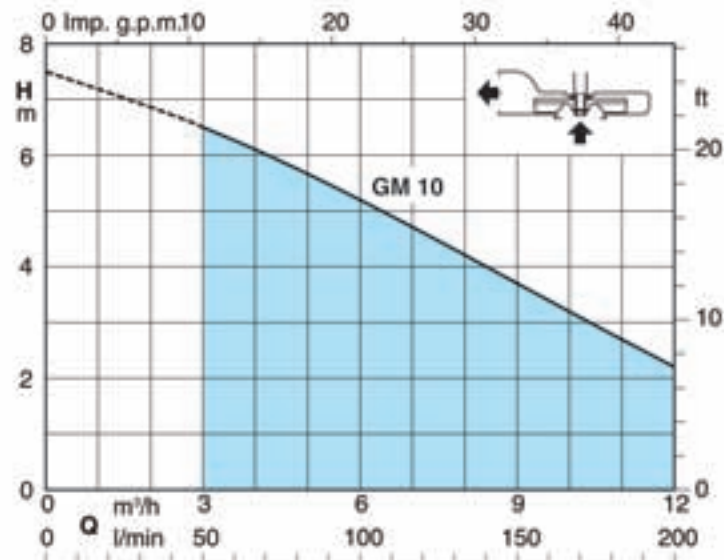

Pumps characteristics

GEO 230-GX..



Features

Automatic collecting and lifting station - for clean water GXR pump series.
- for waste water GXV pump series.

include:

- 1 tank capacity 230 l
- 1 single-phase pump with 5 m cable and float switch
- 1 discharge pipe kit Ø 40 mm in PVC

ON DEMAND

- 1 pump with 10 m cable
- 1 discharge pipe kit Ø 40 mm in PVC with a ball valve and non-return ball valve
- 1 support kit with safety float switch and auto-supplied control panel for remote alarm with horn and flashing light
- extension 300 mm

Single-phase type	1 - 230 V		Q max m³/h	H max m
	kW	A		
GEO 230-GXVM 25-6	0,25	2,5	10,2	5,7
GEO 230-GXVM 25-8	0,37	3,5	12	7,8
GEO 230-GXVM 25-10	0,45	4,5	13,2	9,5
GEO 230-GXRM 9	0,25	2,5	10,2	8,3
GEO 230-GXRM 11	0,37	3,5	12	10,4
GEO 230-GXRM 13	0,45	4,5	13,2	11,7

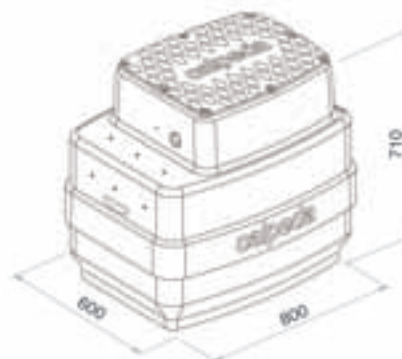

GXVM

GXRM

GXRM, GXVM

Submersible drainage pump in chrome-nickel stainless steel, with vertical delivery port.

GXRM: with open impeller.

GXVM: with free-flow (vortex) impeller.

2-pole induction motor, 50Hz (n = 2900 rpm).

Single-phase 230 V +/-10% with float switch and thermal protector. Incorporated capacitor.

Cable length 5 m.

Liquid temperature up to 50 °C

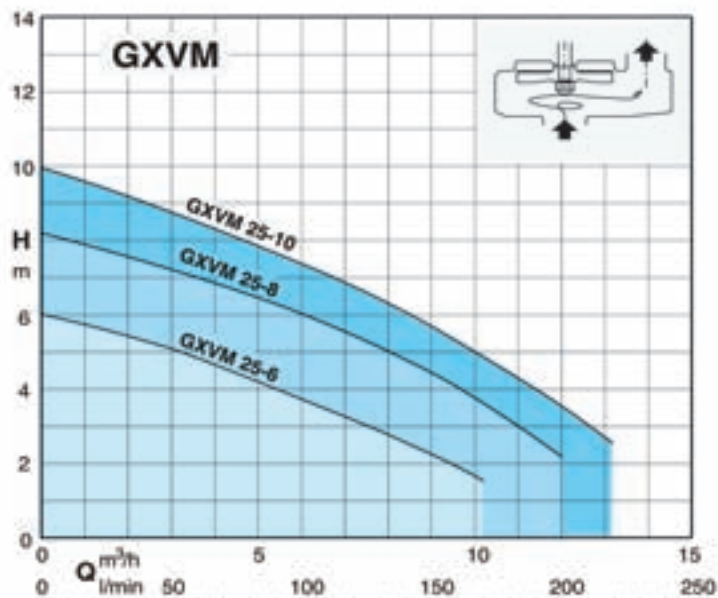
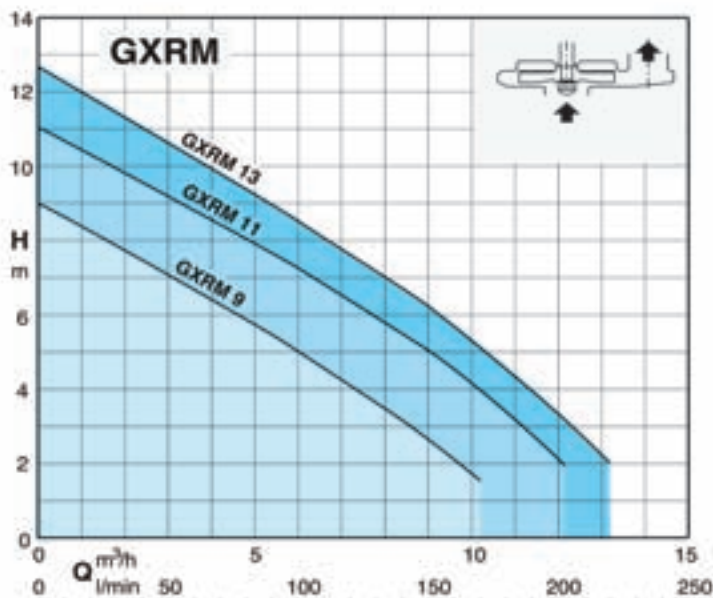

Pumps characteristics

GEO 230-GQR.



Features

Automatic collecting and lifting station for clean water with GQR pump series.

Include:

- 1 tank capacity 230 lt
- 1 pump - single-phase with 10 m cable and float switch
- three-phase with 10 m cable with support and float switch kit
- 1 control box for three-phase version
- 1 discharge pipe kit Ø 50 mm in PVC

ON DEMAND

- 1 discharge pipe kit Ø 50 mm in PVC with a ball valve and non-return ball valve
- 1 support kit with safety float switch and auto-supplied control panel for remote alarm with horn and flashing light
- extension 300 mm

Single-phase type	1 ~ 230 V		Q max m ³ /h	H max m
	kW	A		
GEO 230-GQRM 10-10	0,45	3,1	18	9,5
GEO 230-GQRM 10-12	0,55	3,6	21	11,6
GEO 230-GQRM 10-14	0,75	4,6	24	13,5
GEO 230-GQRM 10-16	0,9	6	27	15,5
GEO 230-GQRM 10-18	1,1	8	30	17,5

Three-phase type	3 ~ 400 V		Q max m ³ /h	H max m
	kW	A		
GEO 230-GQR 10-10	0,45	1,2	18	9,5
GEO 230-GQR 10-12	0,55	1,4	21	11,6
GEO 230-GQR 10-14	0,75	1,6	24	13,5
GEO 230-GQR 10-16	0,9	2,3	27	15,5
GEO 230-GQR 10-18	1,1	2,8	30	17,5
GEO 230-GQR 10-20	1,5	3,8	30	19,5

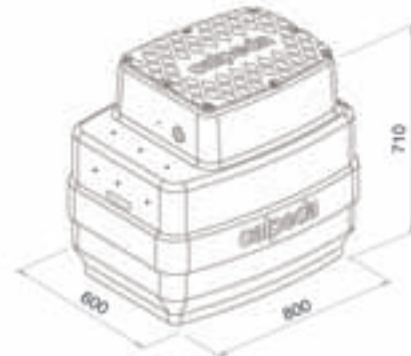

GQR

Single-impeller submersible drainage pump, with vertical delivery port.

GQR: with open impeller.

2-pole induction motor, 50Hz (n = 2900 rpm),

GQR: three-phase 400 V;

GQRM: Single-phase 230 V +/-10% with float switch and thermal protector. Incorporated capacitor.

Cable length 10 m.

Liquid temperature up to 35 °C

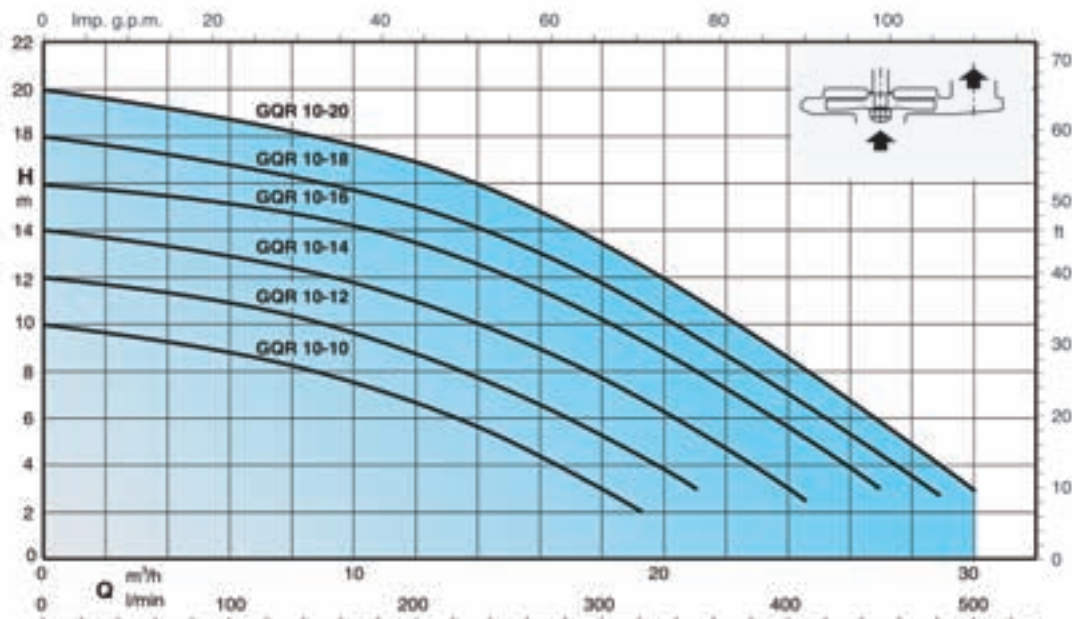

Pumps characteristics

GEO 230-GX..



Features

Automatic waste water collecting and lifting station GX 40 pump series.

include:

- 1 tank capacity 230 lt
- 1 pump - single-phase with 10 m cable and float switch
- three-phase with 10 m cable with support and float switch kit
- 1 control box for three-phase version
- 1 discharge pipe kit Ø 50 mm in PVC

ON DEMAND

- 1 discharge pipe kit Ø 50 mm in PVC with a ball valve and non-return ball valve
- 1 safety float switch (with support for single-phase version) and auto-supplied control panel for remote alarm with horn and flashing light
- extension 300 mm

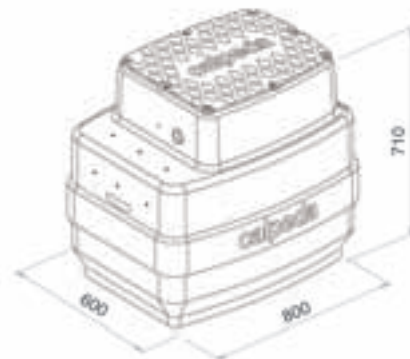

Single-phase type	1 ~ 230 V		Q max m ³ /h	H max m
	kW	A		
GEO 230-GXCM 40-10	0,55	4,6	21	9
GEO 230-GXCM 40-13	0,9	6,6	26	11,6
GEO 230-GXVM 40-7	0,55	4,6	15	6,2
GEO 230-GXVM 40-8	0,75	5,4	18	7,2
GEO 230-GXVM 40-8	0,9	6	21	8,1

Three-phase type	3 ~ 400 V		Q max m ³ /h	H max m
	kW	A		
GEO 230-GXC 40-10	0,55	1,6	21	9
GEO 230-GXC 40-13	0,9	2,3	26	11,6
GEO 230-GXV 40-7	0,55	1,6	15	6,2
GEO 230-GXV 40-8	0,75	2,2	18	7,2
GEO 230-GXV 40-9	0,9	2,3	21	8,1



GXC, GXV

Submersible sewage and drainage pumps in chrome-nickel stainless steel, with vertical delivery port.

GXC, with single-channel impeller,

GXV: with free-flow (vortex) impeller

2-pole induction motor, 50Hz (n = 2900 rpm).

GXC, GXV: three-phase 400 V;

GXCM, GXVM: single-phase 230 V +/-10%, with float switch and thermal protector. Incorporated capacitor.

Cable length 10 m.

Liquid temperature up to 35 °C

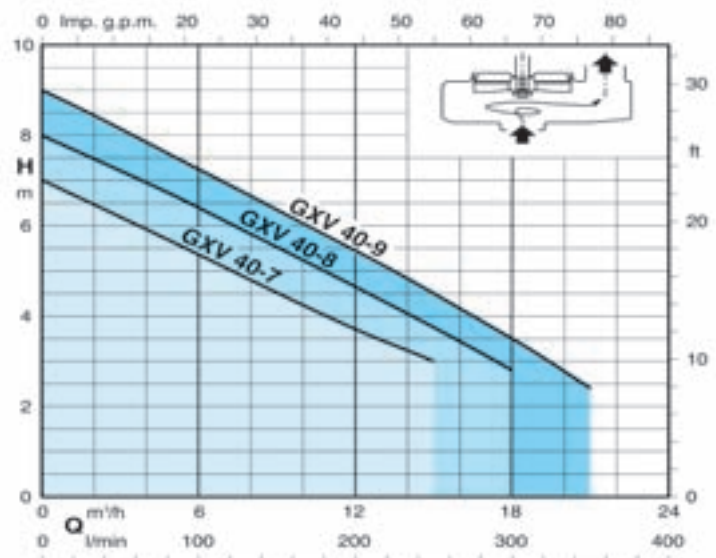
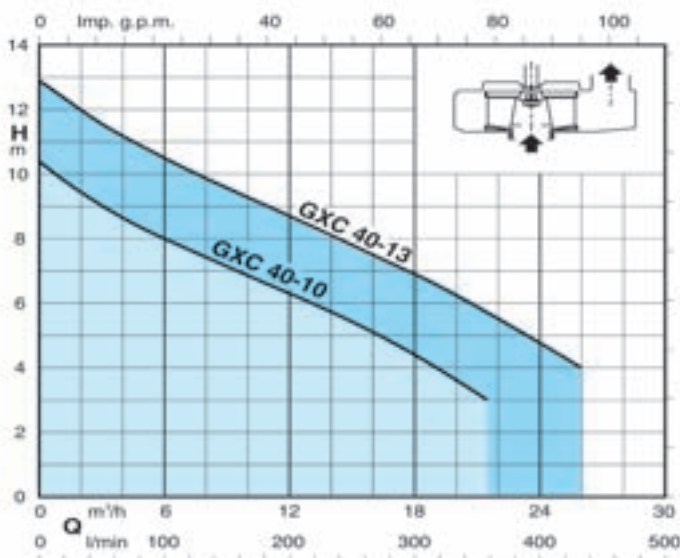

Pumps characteristics



Features

Automatic sewage water collecting and lifting station with grinder pumps GMG series.

Include:

- 1 tank capacity 230 lt
- 1 pump - single-phase with 10 m cable without float switch
- three-phase with 10 m cable
- 1 support kit with float switch
- 1 control box (with capacitor for single-phase motors)
- 1 duck foot coupling kit
- 1 discharge pipe kit Ø 63 mm in PVC with a ball valve and non-return ball valve

ON DEMAND

- 1 safety float switch and auto-supplied control panel for remote alarm with horn and flashing light
- extension 300 mm

Single-phase type	1 ~ 230 V		Q max m ³ /h	H max m
	kW	A		
GEO 230-GMGM 6-40E/A	1,1	7,5	12	5,5
GEO 230-GMGM 6-40D/A	1,1	7,5	14	9
GEO 230-GMGM 6-40C	1,1	7,5	16	15,5
GEO 230-GMGM 6-40B	1,1	7,5	14	19,5
GEO 230-GMGM 6-40A	1,8	10	16	23,5

Three-phase type	3 ~ 400 V		Q max m ³ /h	H max m
	kW	A		
GEO 230-GMG 6-40B	1,4	3,5	14	19,5
GEO 230-GMG 6-40A	2,4	5	16	23,5

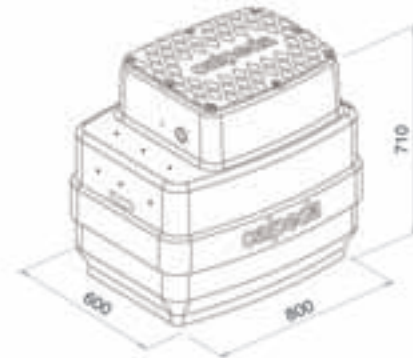

GMGM

Submersible pumps with high power grinder.
2-pole induction motor, 50Hz (n ≈ 2900 rpm)

GMG: three-phase 400 V;

GMGM: Single-phase 230 V +/- 10% complete control box with thermal protector and capacitors (without float switch).
10 m cable.

Liquid temperature up to 40 °C.

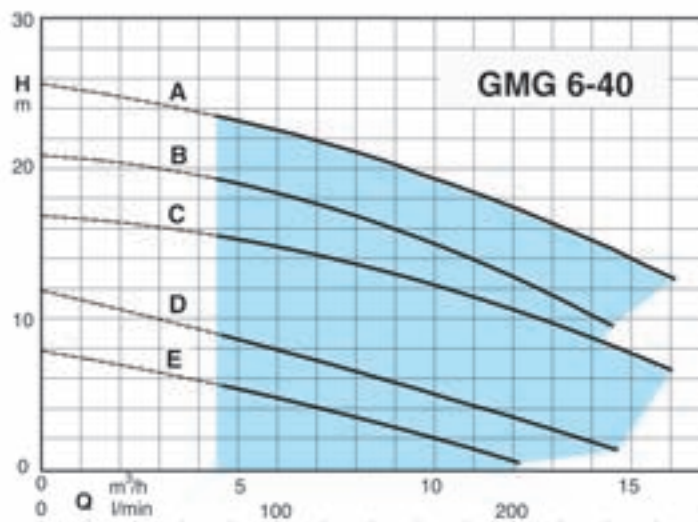

Pumps characteristics

GEO 230-GQS



Features

Automatic waste water collecting and lifting station GQS series.

include:

- 1 tank capacity 230 lt
- 1 pump - single-phase 10 m cable and float switch
 - three-phase with 10 cable with support kit and float switch
- 1 control box for three-phase version
- 1 duck foot coupling kit
- 1 discharge pipe kit Ø 63 mm in PVC with a ball valve and non-return ball valve

ON DEMAND

- 1 safety float switch (with support for single-phase version) and auto-supplied control panel for remote alarm with horn and flashing light
 - extension 300 mm

Single-phase type	1 ~ 230 V		Q max m ³ /h	H max m
	kW	A		
GEO 230-GQSM 50-8	0,55	4,3	24	7,4
GEO 230-GQSM 50-9	0,75	4,8	27	8,8
GEO 230-GQSM 50-11	0,9	6,6	33	10,5
GEO 230-GQSM 50-13	1,1	8,4	36	12,5

Three-phase type	3 ~ 400 V		Q max m ³ /h	H max m
	kW	A		
GEO 230-GQS 50-8	0,55	1,5	24	7,4
GEO 230-GQS 50-9	0,75	1,8	27	8,8
GEO 230-GQS 50-11	0,9	2,3	33	10,5
GEO 230-GQS 50-13	1,1	3	36	12,5
GEO 230-GQS 50-15	1,5	4	36	14,4

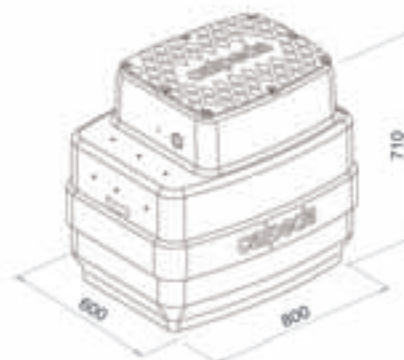

GQS

Single-impeller submersible pumps, with vertical delivery port.

GQS: with free-flow (vortex) impeller

2-pole induction motor, 50Hz (n = 2900 rpm)

GQS: three-phase 400 V:

GQSM: single-phase 230 V +/-10%, with float switch and thermal protector.
Incorporated capacitor.

Cable length 10 m.

Liquid temperature up to 35 °C

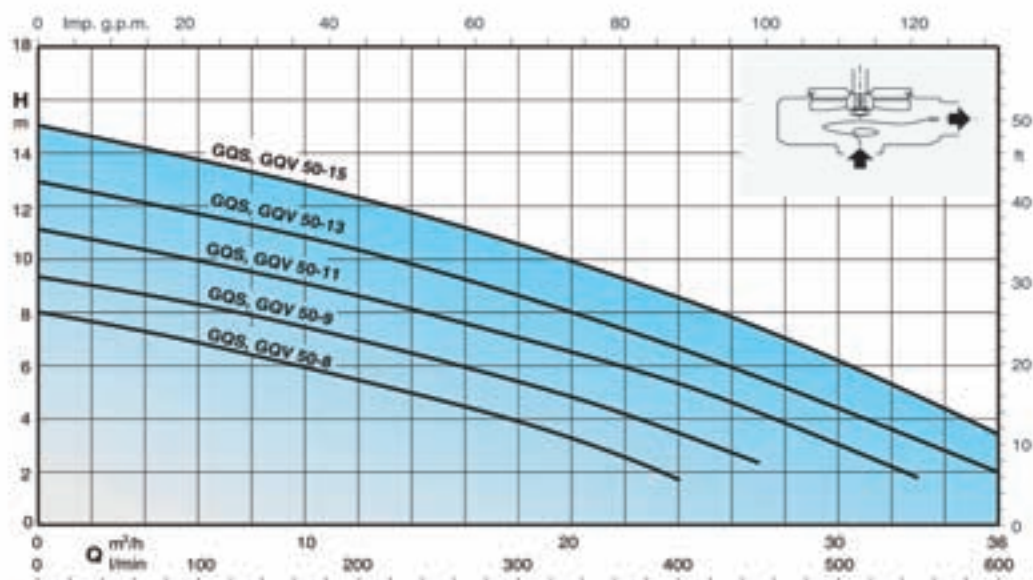

Pumps characteristics



GEO 230-GQV

Features

Automatic waste water collecting and lifting station GQV series.

include:

- 1 tank capacity 230 lt
- 1 pump - single-phase with 10 m cable, without float switch
- three-phase with 10 cable, without float switch
- 1 support kit with float switch
- 1 control box
- 1 duck foot coupling kit
- 1 discharge pipe kit Ø 63 mm in PVC/inox with a ball valve and non-return ball valve

ON DEMAND

- 1 safety float switch and auto-supplied control panel for remote alarm with horn and flashing light
- extension 300 mm

Single-phase type	1 ~ 230 V		Q max m ³ /h	H max m
	kW	A		
GEO 230-GQVM 50-8	0,55	4,3	24	7,4
GEO 230-GQVM 50-9	0,75	4,8	27	8,8
GEO 230-GQVM 50-11	0,9	6,6	33	10,5
GEO 230-GQVM 50-13	1,1	8,4	36	12,5

Three-phase type	3 ~ 400 V		Q max m ³ /h	H max m
	kW	A		
GEO 230-GQV 50-8	0,55	1,5	24	7,4
GEO 230-GQV 50-9	0,75	1,8	27	8,8
GEO 230-GQV 50-11	0,9	2,3	33	10,5
GEO 230-GQV 50-13	1,1	3	36	12,5
GEO 230-GQV 50-15	1,5	4	36	14,4

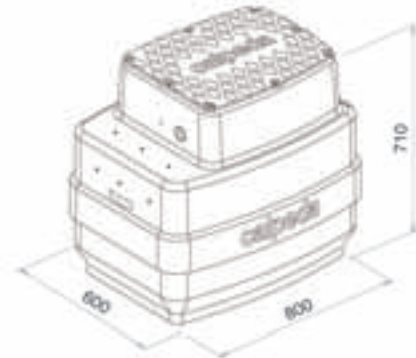

GQV

Single-impeller submersible pumps, with horizontal delivery port.

GQV: with free-flow (vortex) impeller

2-pole induction motor, 50Hz (n = 2900 rpm)

GQV: three-phase 400 V;

GQVM: single-phase 230 V +/-10%, with thermal protector, with built-in capacitor (without float switch).

Cable length 10 m.

Liquid temperature up to 35 °C

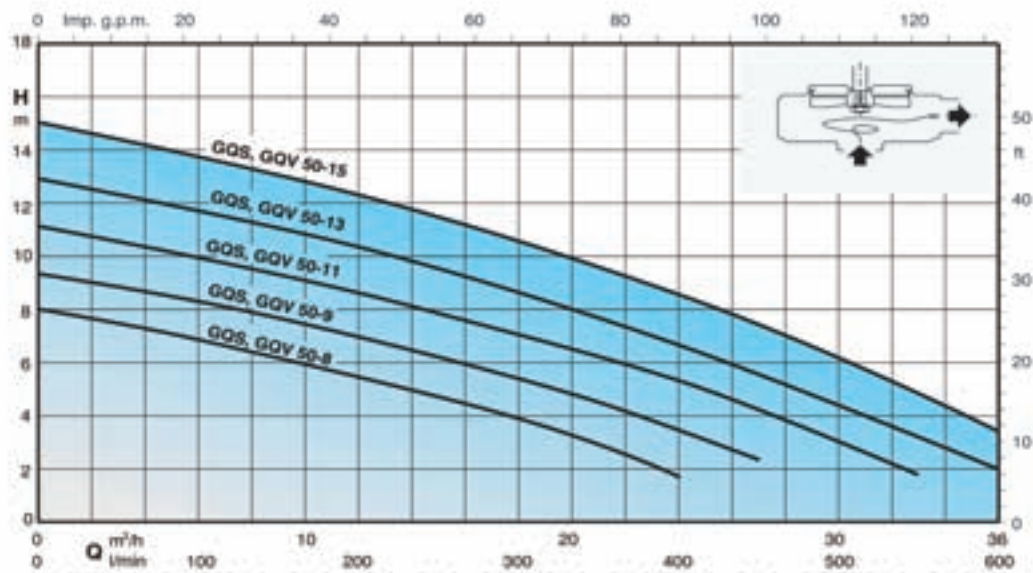

Pumps characteristics

GEO 230-GM..



Features

Automatic waste water collecting and lifting station GMV, GMC series.

include:

- 1 tank capacity 230 lt
- 1 pump - single-phase 10 m cable and float switch
- three-phase with 10 cable with support kit and float switch
- 1 control box for three-phase version
- 1 discharge pipe kit Ø 63 mm in PVC with a ball valve and non-return ball valve

ON DEMAND

- 1 safety float switch (with support for single-phase version) and auto-supplied control panel for remote alarm with horn and flashing light
- extension 300 mm

Single-phase type	1 ~ 230 V		Q max m³/h	H max m
	kW	A		
GEO 230-GMCM 50CE	0,75	4,5	36	9,5
GEO 230-GMCM 50BE	1,1	6,5	42	12,5
GEO 230-GMVM 50CE	0,75	4,5	31	8
GEO 230-GMVM 50BE	1,1	6,5	35	9,5

Three-phase type	3 ~ 400 V		Q max m³/h	H max m
	kW	A		
GEO 230-GMC 50CE	0,75	1,9	36	9,5
GEO 230-GMC 50BE	1,1	2,7	42	12,5
GEO 230-GMC 50AE	1,5	3,8	48	14,5
GEO 230-GMV 50CE	0,75	1,9	31	8
GEO 230-GMV 50BE	1,1	2,7	35	9,5
GEO 230-GMV 50AE	1,5	3,8	39	11,5

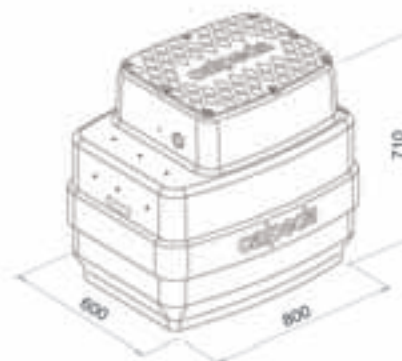

GMC, GMV

Submersible sewage and drainage pumps.

GMC, with single-channel impeller.

GMV, with free-flow (vortex) impeller.

2-pole induction motor, 50Hz (n = 2900 rpm)

GMV, GMC: three-phase 400 V;

with 2 built-in thermal protectors to be connected to the control panel.

GMVM, GMVM: single-phase 230 V ± 10%, built-in thermal protector and built-in capacitor.

Float switch for automatic operation.

Cable length 10 m.

Liquid temperature up to 35 °C.

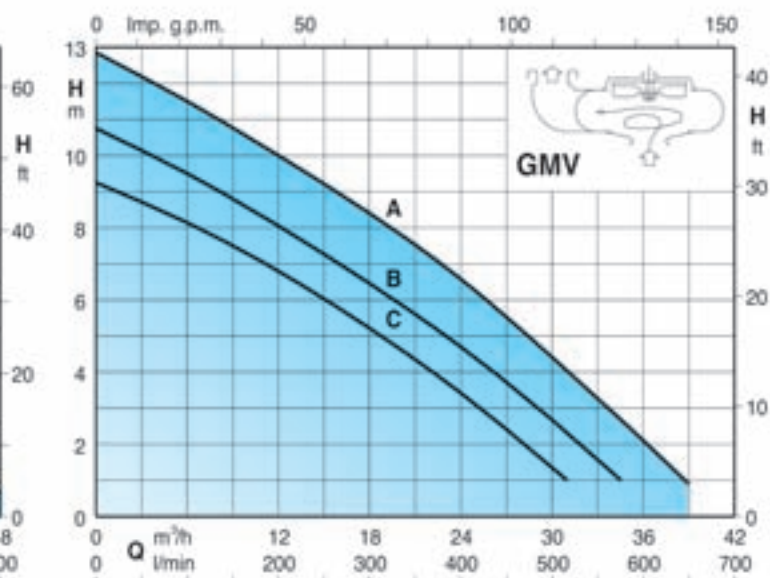
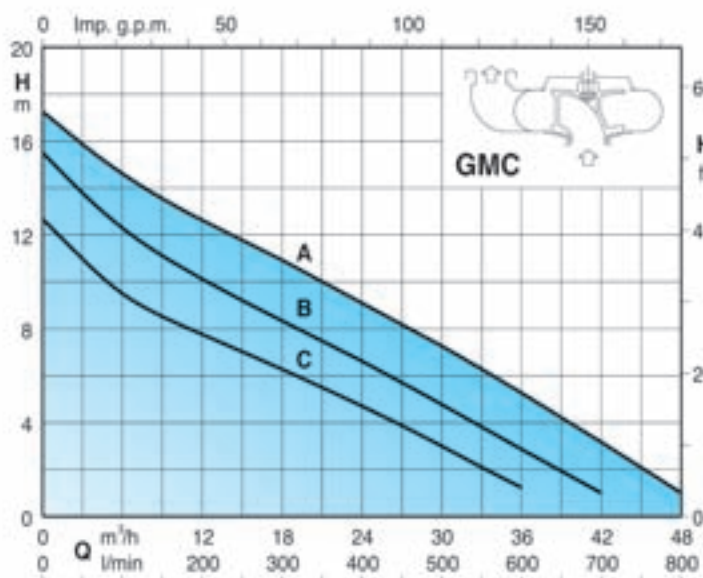

Pumps characteristics



Features

Automatic waste water collecting and lifting station GMV, GMC series.

Include:

- 1 tank capacity 230 lt
- 1 pump - single-phase 10 m cable and float switch
 - three-phase with 10 cable with support kit and float switch
- 1 control box for three-phase version
- 1 duck foot coupling kit
- 1 discharge pipe kit Ø 63 mm in PVC with a ball valve and non-return ball valve

ON DEMAND

- 1 safety float switch (with support for single-phase version) and auto-supplied control panel for remote alarm with horn and flashing light - extension 300 mm

Single-phase type	1 ~ 230 V		Q max m ³ /h	H max m
	kW	A		
GEO 230-GMCM 50-65C	0,75	4,5	36	9,5
GEO 230-GMCM 50-65B	1,1	6,5	42	12,5
GEO 230-GMVM 50-65C	0,75	4,5	31	8
GEO 230-GMVM 50-65B	1,1	6,5	35	9,5

Three-phase type	3 ~ 400 V		Q max m ³ /h	H max m
	kW	A		
GEO 230-GMC 50-65C	0,75	1,9	36	9,5
GEO 230-GMC 50-65B	1,1	2,7	42	12,5
GEO 230-GMC 50-65A	1,5	3,8	48	14,5
GEO 230-GMV 50-65C	0,75	1,9	31	8
GEO 230-GMV 50-65B	1,1	2,7	35	9,5
GEO 230-GMV 50-65A	1,5	3,8	39	11,5

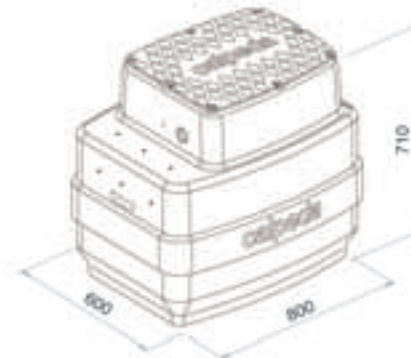

GMC, GMV

Submersible sewage and drainage pumps.

GMC, with single-channel impeller.

GMV, with free-flow (vortex) impeller.

2-pole induction motor, 50Hz (n = 2900 rpm)

GMV, GMC: three-phase 400 V;

with 2 built-in thermal protectors to be connected to the control panel.

GMVM, GMVM: single-phase 230 V ± 10%, built-in thermal protector and built-in capacitor.

Float switch for automatic operation.

Cable length 10 m.

Liquid temperature up to 35 °C.

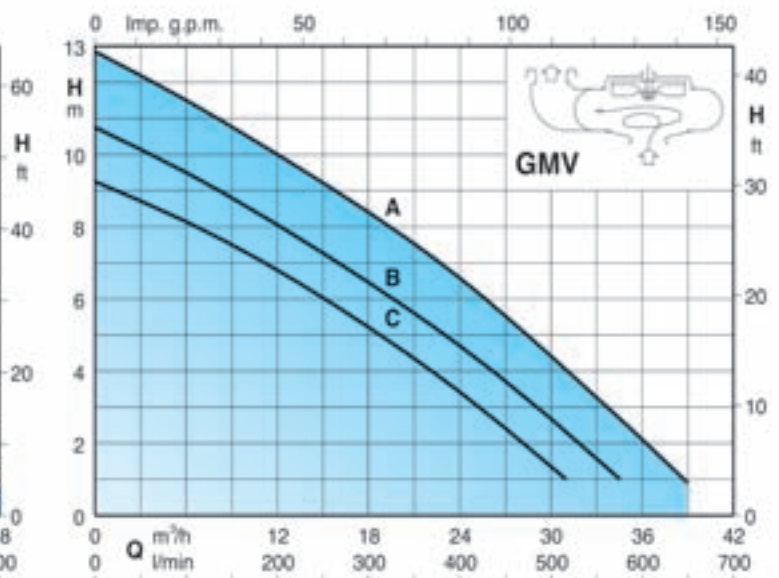
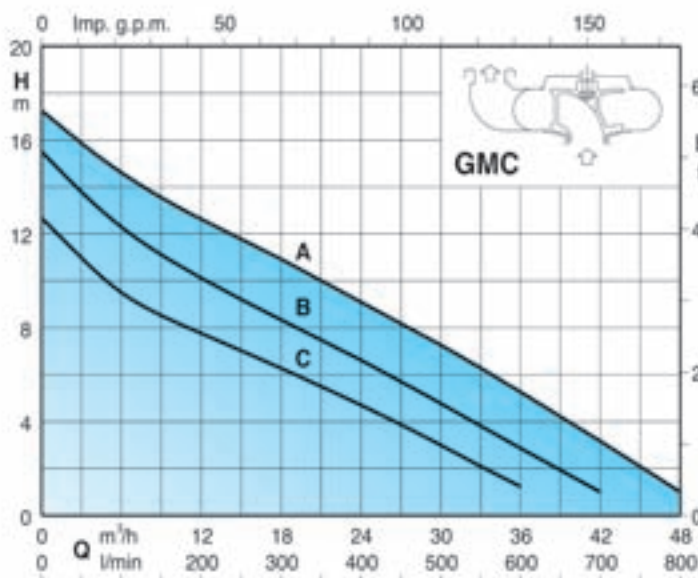

Pumps characteristics

GEO 500-GM 10



Features

Automatic clear water collecting and lifting station with GM 10 pump series.

include:

- 1 tank capacity 500 lt
- 2 single-phase pump with 5 m cable without float switch
- 1 support kit with 2 float switch
- 1 control box
- 2 discharge pipe kit Ø 40 mm in PVC

ON DEMAND

- 2 single-phase pumps with 10 m cable, without float switch
- 2 discharge pipe kit Ø 40 mm in PVC with a ball valve and non-return ball valve
- 1 safety float switch and auto-supplied control panel for remote alarm with horn and flashing light
- extension 300 mm

Single-phase type	1 – 230 V		Q max m ³ /h	H max m
	kW	A		
GEO 500-2GM 10	0,3x2	1,75x2	12x2	6,5

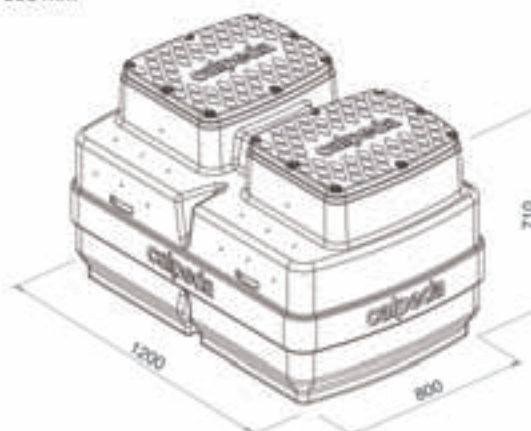

GM 10

Submersible drainage pump constructed from composite polymers.
 Shaft of chrome steel AISI 430.
 2-pole induction motor, 50Hz (n = 2900 rpm).
 Single-phase 230 V +/-10% with thermal protector (without float switch).
 5 m cable and control box with capacitor.
 Liquid temperature up to 35 °C

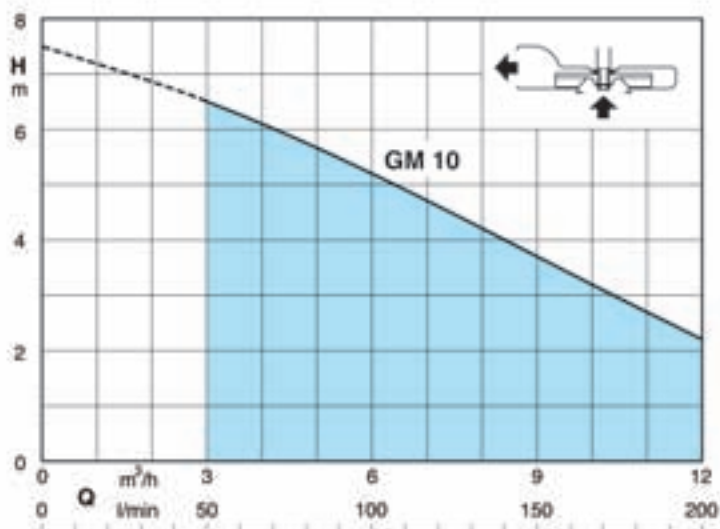

Pumps characteristics

GEO 500-2GX..



Features

Automatic collecting and lifting station - for clean water with GXR pump series
- for waste water with GXV pump series.

include:

- 1 tank capacity 500 lt
- 2 single-phase pump with 5 m cable without float switch
- 1 support kit with 2 float switch
- 1 control box
- 2 discharge pipe kit Ø 40 mm in PVC

ON DEMAND

- 2 single-phase pumps with 10 m cable, without float switch
- 2 discharge pipe kit Ø 40 mm in PVC with a ball valve and non-return ball valve
- 1 safety float switch and auto-supplied control panel for remote alarm with horn and flashing light
- extension 300 mm

Single-phase type	1 ~ 230 V		Q max m ³ /h	H max m
	kW	A		
GEO 500-2GXVM 25-6	0,25x2	2,5x2	10,2x2	5,7
GEO 500-2GXVM 25-8	0,37x2	3,5x2	12x2	7,8
GEO 500-2GXVM 25-10	0,45x2	4,5x2	13,2x2	9,5
GEO 500-2GXRM 9	0,25x2	2,5x2	10,2x2	8,3
GEO 500-2GXRM 11	0,37x2	3,5x2	12x2	10,4
GEO 500-2GXRM 13	0,45x2	4,5x2	13,2x2	11,7

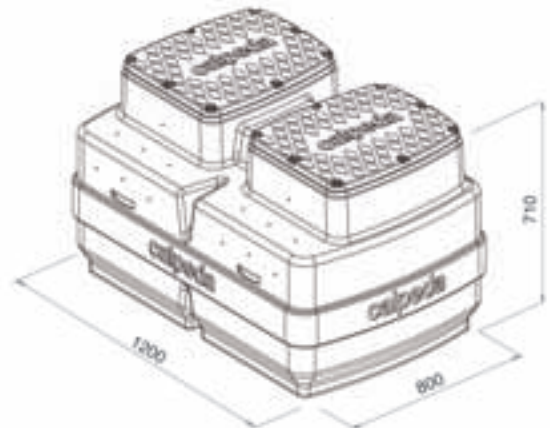

GXRM

GXVM

GXRM, GXVM

Submersible drainage pump in chrome-nickel stainless steel, with vertical delivery port.

GXRM: with open impeller.

GXVM: with free-flow (vortex) impeller.

2-pole induction motor, 50Hz (n = 2900 rpm).

Single-phase 230 V +/-10% with thermal protector. Incorporated capacitor.

Cable length 5 m.

Liquid temperature up to 50 °C

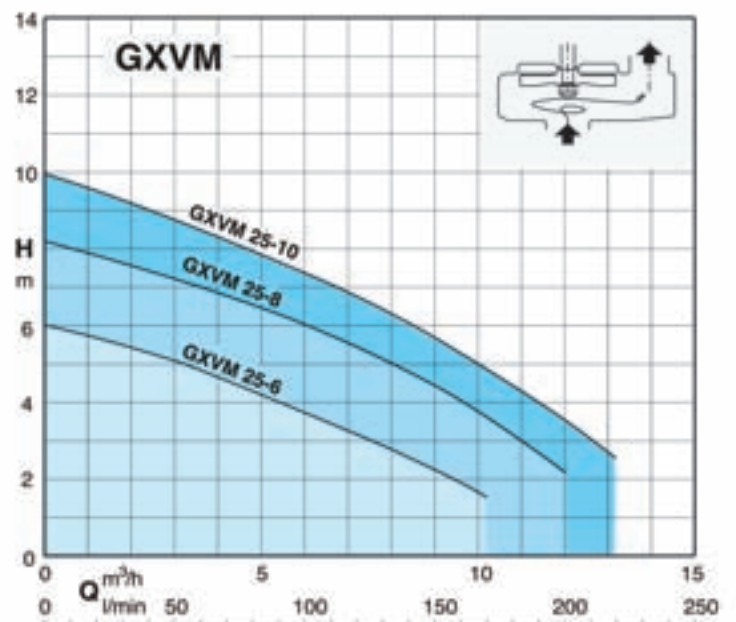
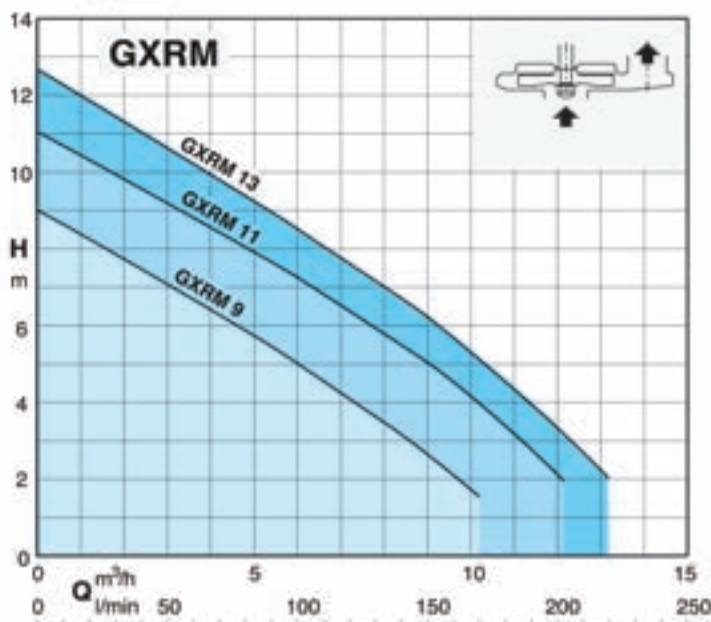

Pumps characteristics

GEO 500-2GQR

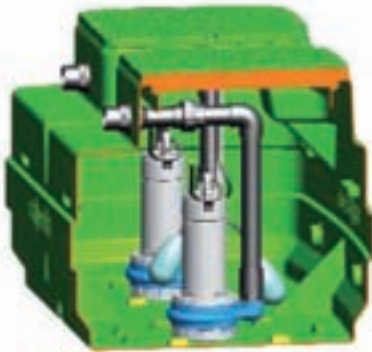

Features

Automatic collecting and lifting station for clean water with GQR pump series

Include:

- 1 tank capacity 500 lt
- 2 pumps - single-phase with 10 m cable without float switch
 - three-phase with 10 m cable
- 1 support kit with 2 float switch
- 1 control box
- 2 discharge pipe kit Ø 50 mm in PVC

ON DEMAND

- 2 discharge pipe kit Ø 50 mm in PVC with a ball valve and non-return ball valve
- 1 safety float switch and auto-supplied control panel for remote alarm with horn and flashing light
 - extension 300 mm

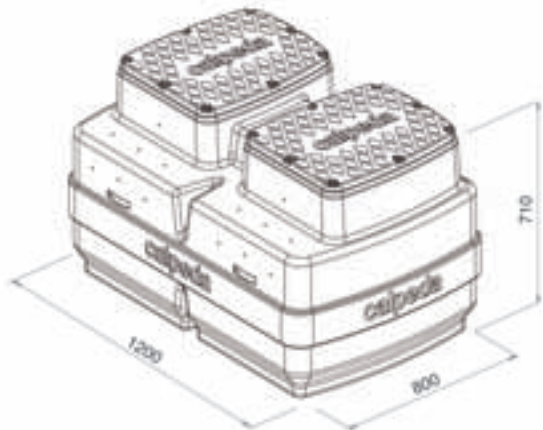

Single-phase type	1 ~ 230 V		Q max m ³ /h	H max m
	kW	A		
GEO 500-2GQRM 10-10	0,45x2	3,1x2	18x2	9,5
GEO 500-2GQRM 10-12	0,55x2	3,6x2	21x2	11,6
GEO 500-2GQRM 10-14	0,75x2	4,6x2	24x2	13,5
GEO 500-2GQRM 10-16	0,9x2	6x2	27x2	15,5
GEO 500-2GQRM 10-18	1,1x2	8x2	30x2	17,5

Three-phase type	3 ~ 400 V		Q max m ³ /h	H max m
	kW	A		
GEO 500-2GQR 10-10	0,45x2	1,2x2	18x2	9,5
GEO 500-2GQR 10-12	0,55x2	1,4x2	21x2	11,6
GEO 500-2GQR 10-14	0,75x2	1,6x2	24x2	13,5
GEO 500-2GQR 10-16	0,9x2	2,3x2	27x2	15,5
GEO 500-2GQR 10-18	1,1x2	2,8x2	30x2	17,5
GEO 500-2GQR 10-20	1,5x2	3,8x2	30x2	19,5



GQR

Single-impeller submersible drainage pump, with vertical delivery port.

GQR: with open impeller.

2-pole induction motor, 50Hz (n = 2900 rpm).

GQR: three-phase 400 V;

GQRM: Single-phase 230 V +/-10% with thermal protector and incorporated capacitor (without float switch).

Cable length 10 m.

Liquid temperature up to 35 °C.

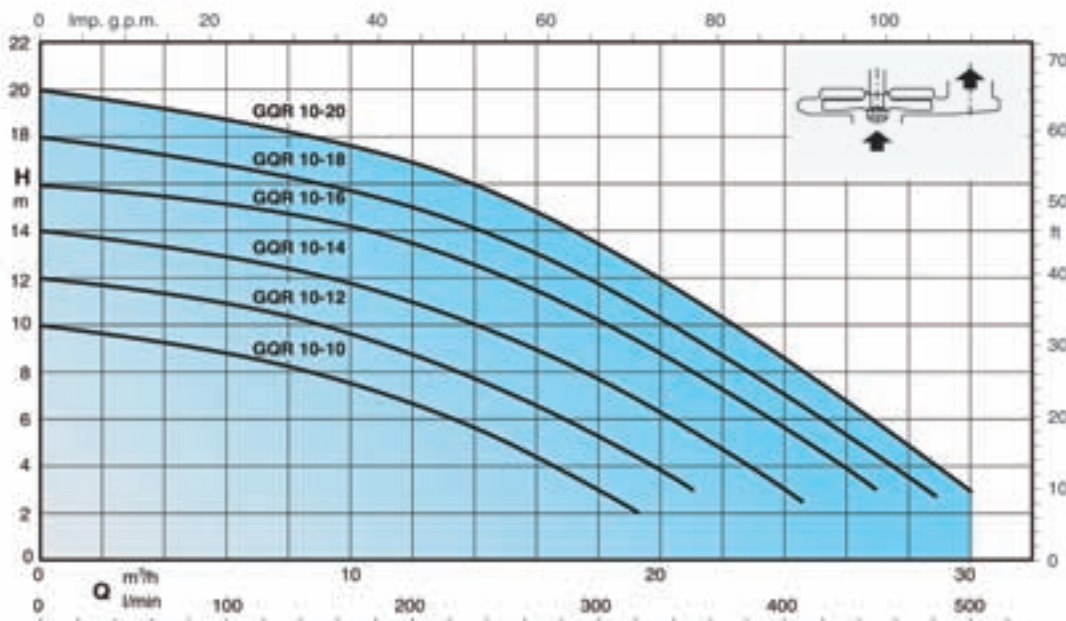

Pumps characteristics

GEO 500-2GX...



Features

Automatic waste water collecting and lifting station with GX 40 pump series.

Include:

- 1 tank capacity 500 lt
- 2 pumps - single-phase with 10 m cable without float switch
- three-phase with 10 m cable
- 1 support kit with 2 float switch
- 1 electric control box
- 2 discharge pipe kit Ø 50 mm in PVC

ON DEMAND

- 2 discharge pipe kit Ø 50 mm in PVC with a ball valve and non-return ball valve
- 1 safety float switch and auto-supplied control panel for remote alarm with horn and flashing light
- extension 300 mm

Single-phase type	1 – 230 V		Q max m ³ /h	H max m
	kW	A		
GEO 500-2GXCM 40-10	0,55x2	4,6x2	21x2	9
GEO 500-2GXCM 40-13	0,9x2	6,6x2	26x2	11,6
GEO 500-2GXVM 40-7	0,55x2	4,6x2	15x2	6,2
GEO 500-2GXVM 40-8	0,75x2	5,4x2	18x2	7,2
GEO 500-2GXVM 40-8	0,9x2	6x2	21x2	8,1

Three-phase type	3 – 400 V		Q max m ³ /h	H max m
	kW	A		
GEO 500-2GXC 40-10	0,55x2	1,6x2	21x2	9
GEO 500-2GXC 40-13	0,9x2	2,3x2	26x2	11,6
GEO 500-2GXV 40-7	0,55x2	1,6x2	15x2	6,2
GEO 500-2GXV 40-8	0,75x2	2,2x2	18x2	7,2
GEO 500-2GXV 40-9	0,9x2	2,3x2	21x2	8,1

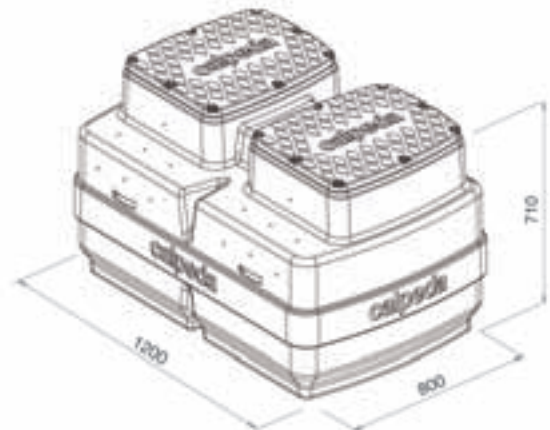

GXC, GXV

Submersible sewage and drainage pumps in chrome-nickel stainless steel, with vertical delivery port.

GXC, with single-channel impeller.

GXV: with free-flow (vortex) impeller

2-pole induction motor, 50Hz (n = 2900 rpm).

GXC, GXV: three-phase 400 V;

GXCM, GXVM: single-phase 230 V +/-10%, with thermal protector and incorporated capacitor (without float switch).

Cable length 10 m.

Liquid temperature up to 35 °C

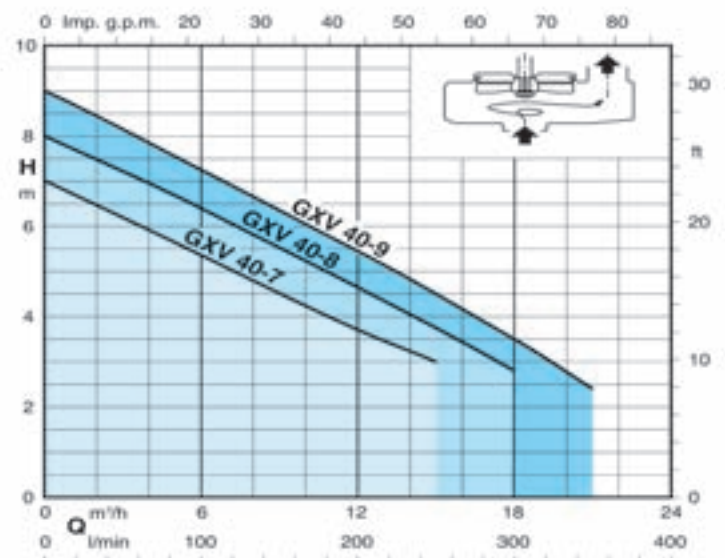
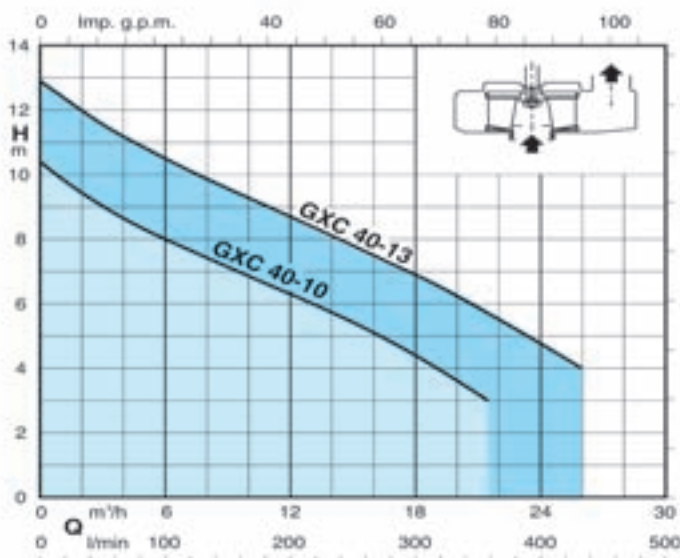

Pumps characteristics



GEO 500-2GMGM

Features

Automatic sewage water collecting and lifting station with grinder pumps GMG series.

include:

- 1 tank capacity 500 lt
- 2 pumps - single-phase 10 m cable without float switch
- three-phase with 10 cable
- 1 support kit with 2 float switch
- 1 electric control box (with capacitor for single-phase motors)
- 2 duck foot coupling kit
- 2 discharge pipe kit Ø 63 mm in PVC with a ball valve and non-return ball valve

ON DEMAND

- 1 safety float switch and auto-supplied control panel for remote alarm with horn and flashing light
- extension 300 mm

Single-phase type	1 ~ 230 V		Q max m³/h	H max m
	kW	A		
GEO 500-2GMGM 6-40E/A	1,1x2	7,5x2	12x2	5,5
GEO 500-2GMGM 6-40D/A	1,1x2	7,5x2	14x2	9
GEO 500-2GMGM 6-40C	1,1x2	7,5x2	16x2	15,5
GEO 500-2GMGM 6-40B	1,1x2	7,5x2	14x2	19,5
GEO 500-2GMGM 6-40A	1,8x2	10x2	16x2	23,5

Three-phase type	3 ~ 400 V		Q max m³/h	H max m
	kW	A		
GEO 500-2GMGM 6-40B	1,4x2	3,5x2	14x2	19,5
GEO 500-2GMGM 6-40A	2,4x2	5x2	16x2	23,5

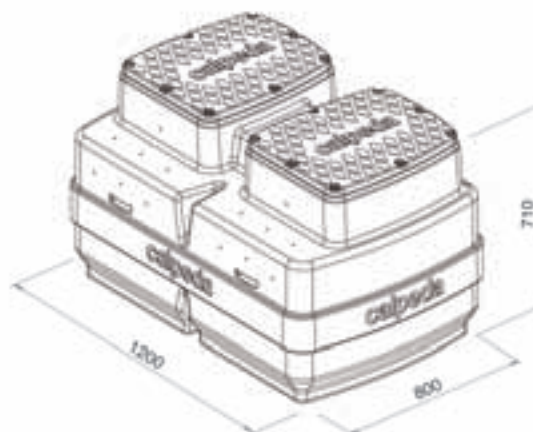

GMGM

Submersible pumps with high power grinder.
2-pole induction motor, 50Hz (n = 2900 rpm)

GMG: three-phase 400 V;

GMGM: Single-phase 230 V +/-10% complete control box with thermal protector and capacitors (without float switch).

10 m cable.

Liquid temperature up to 40 °C.

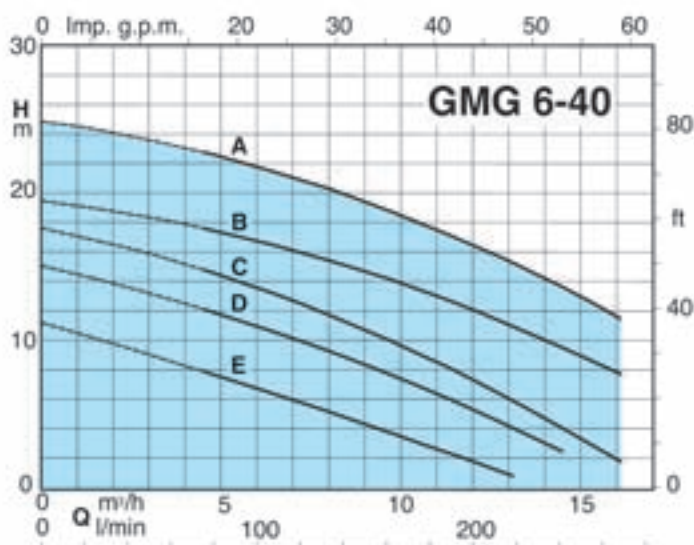

Pumps characteristics

GEO 500-2GQS

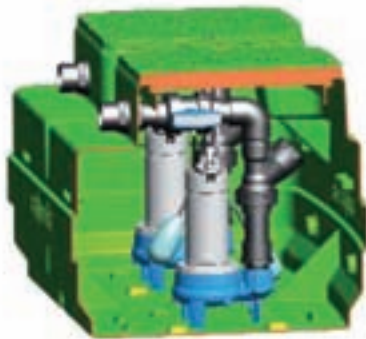

Features

Automatic waste water collecting and lifting station GQS series.

include:

- 1 tank capacity 500 lt
- 2 pumps - single-phase 10 m cable without float switch
- three-phase with 10 cable
- 1 support kit with 2 float switch
- 1 control box for three-phase version
- 2 discharge pipe kit Ø 63 mm in PVC with a ball valve and non-return ball valve

ON DEMAND

- 1 safety float switch and auto-supplied control panel for remote alarm with horn and flashing light
- extension 300 mm

Single-phase type	1 ~ 230 V		Q max m ³ /h	H max m
	kW	A		
GEO 500-2GQSM 50-8	0,55x2	4,3x2	24x2	7,4
GEO 500-2GQSM 50-9	0,75x2	4,8x2	27x2	8,8
GEO 500-2GQSM 50-11	0,9x2	6,6x2	33x2	10,5
GEO 500-2GQSM 50-13	1,1x2	8,4x2	36x2	12,5

Three-phase type	3 ~ 400 V		Q max m ³ /h	H max m
	kW	A		
GEO 500-2GQV 50-8	0,55x2	1,5x2	24x2	7,4
GEO 500-2GQS 50-9	0,75x2	1,8x2	27x2	8,8
GEO 500-2GQS 50-11	0,9x2	2,3x2	33x2	10,5
GEO 500-2GQS 50-13	1,1x2	3x2	36x2	12,5
GEO 500-2GQS 50-15	1,5x2	4x2	36x2	14,4

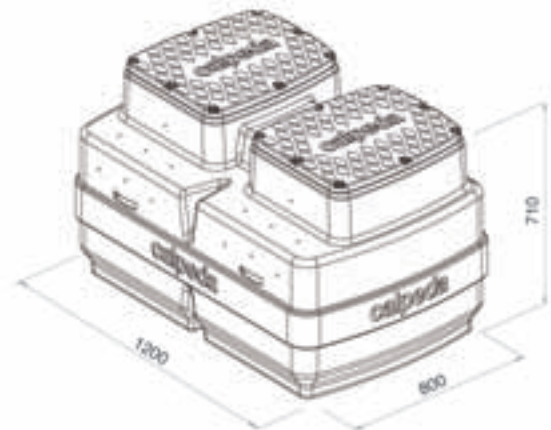

GQS

Single-impeller submersible pumps, with vertical delivery port.

GQS: with free-flow (vortex) impeller
2-pole induction motor, 50Hz (n = 2900 rpm)

GQS: three-phase 400 V;

GQSM: single-phase 230 V +/-10%, with thermal protector, with built-in capacitor (without float switch).
10 m cable.

Liquid temperature up to 35 °C

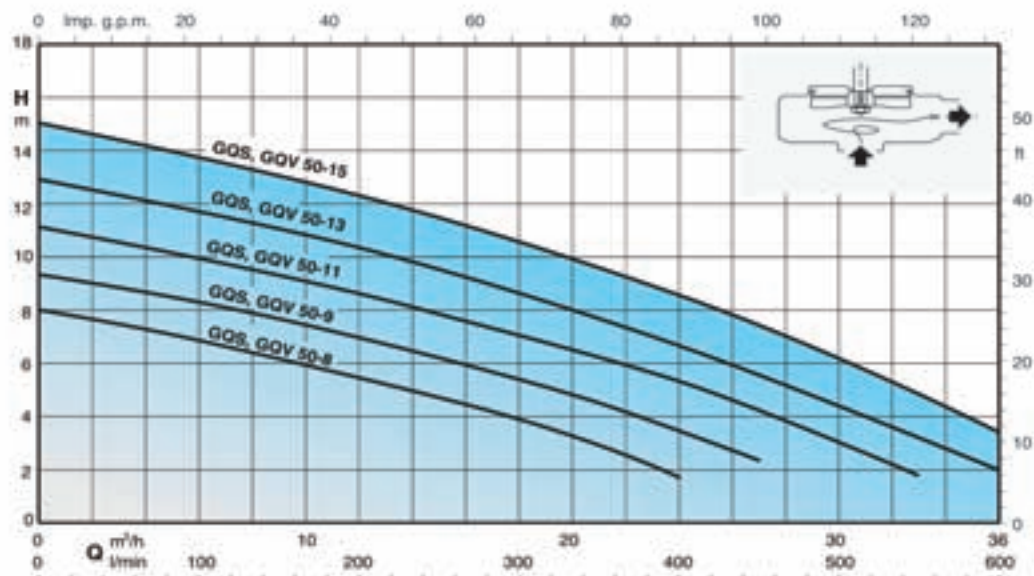

Pumps characteristics



GEO 500-2GQV

Features

Automatic waste water collecting and lifting station with GQV pump series.

include:

- 1 tank capacity 500 lt
- 2 pumps - single-phase 10 m cable without float switch
 - three-phase with 10 cable
- 1 support kit with 2 float switch
- 1 control box
- 2 duck foot coupling kit
- 2 discharge pipe kit Ø 63 mm in PVC with a ball valve and non-return ball valve

ON DEMAND

- 1 safety float switch and auto-supplied control panel for remote alarm with horn and flashing light
- extension 300 mm

Single-phase type	1 ~ 230 V		Q max m ³ /h	H max m
	kW	A		
GEO 500-2GQVM 50-8	0,55x2	4,3x2	24x2	7,4
GEO 500-2GQVM 50-9	0,75x2	4,8x2	27x2	8,8
GEO 500-2GQVM 50-11	0,9x2	6,6x2	33x2	10,5
GEO 500-2GQVM 50-13	1,1x2	8,4x2	36x2	12,5

Three-phase type	3 ~ 400 V		Q max m ³ /h	H max m
	kW	A		
GEO 500-2GQV 50-8	0,55x2	1,5x2	24x2	7,4
GEO 500-2GQV 50-9	0,75x2	1,8x2	27x2	8,8
GEO 500-2GQV 50-11	0,9x2	2,3x2	33x2	10,5
GEO 500-2GQV 50-13	1,1x2	3x2	36x2	12,5
GEO 500-2GQV 50-15	1,5x2	4x2	36x2	14,4

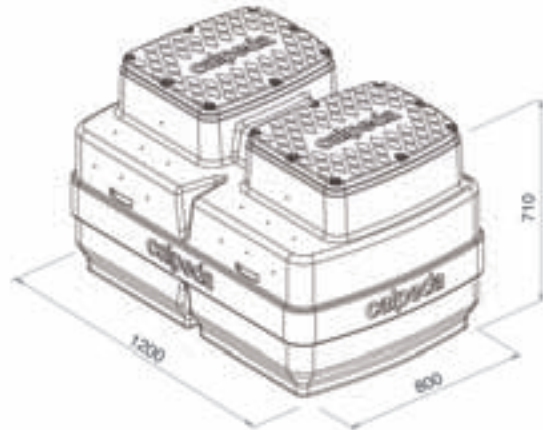

GQV

Single-impeller submersible pumps, with horizontal delivery port.

GQV: with free-flow (vortex) impeller

2-pole induction motor, 50Hz (n = 2900 rpm)

GQV: three-phase 400 V;

GQVM: single-phase 230 V +/-10%, with thermal protector, with built-in capacitor (without float switch), 10 m cable.

Liquid temperature up to 35 °C

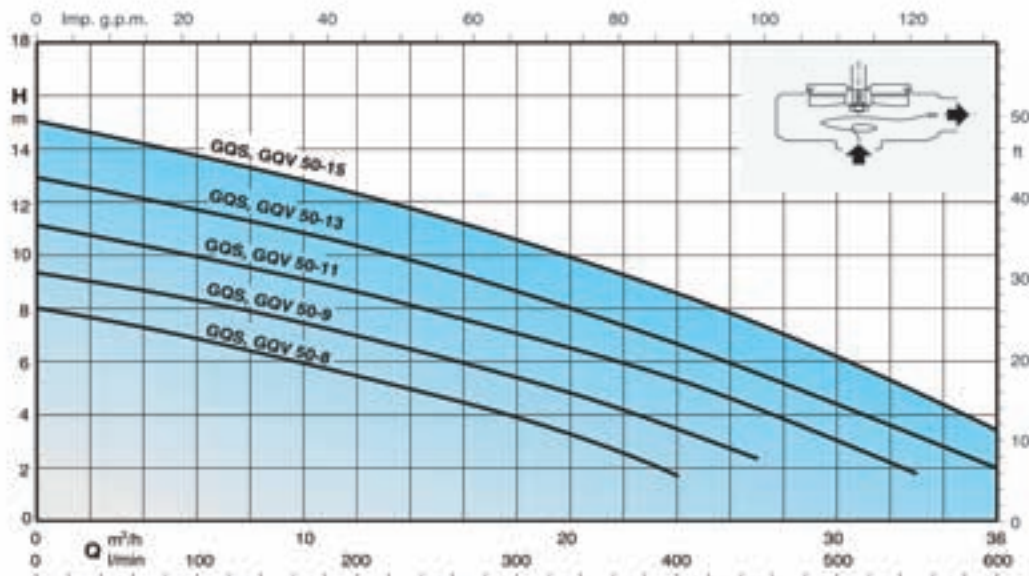

Pumps characteristics

GEO 500-2GM..



Features

Automatic waste water collecting and lifting station GMV, GMC series.

Include:

- 1 tank capacity 500 lt
- 2 pumps - single-phase 10 m cable without float switch
- three-phase with 10 cable
- 1 support kit with 2 float switch
- 1 control box for three-phase version
- 2 discharge pipe kit Ø 63 mm in PVC with a ball valve and non-return ball valve

ON DEMAND

- 1 safety float switch and auto-supplied control panel for remote alarm with horn and flashing light
- extension 300 mm

Single-phase type	1 ~ 230 V		Q max m ³ /h	H max m
	kW	A		
GEO 500-2GMCM 50CE	0,75x2	4,5x2	36x2	9,5
GEO 500-2GMCM 50BE	1,1x2	6,5x2	42x2	12,5
GEO 500-2GMVM 50CE	0,75x2	4,5x2	31x2	8
GEO 500-2GMVM 50BE	1,1x2	6,5x2	35x2	9,5

Three-phase type	3 ~ 400 V		Q max m ³ /h	H max m
	kW	A		
GEO 500-2GMC 50CE	0,75x2	1,9x2	36x2	9,5
GEO 500-2GMC 50BE	1,1x2	2,7x2	42x2	12,5
GEO 500-2GMC 50AE	1,5x2	3,8x2	48x2	14,5
GEO 500-2GMV 50CE	0,75x2	1,9x2	31x2	8
GEO 500-2GMV 50BE	1,1x2	2,7x2	35x2	9,5
GEO 500-2GMV 50AE	1,5x2	3,8x2	39x2	11,5

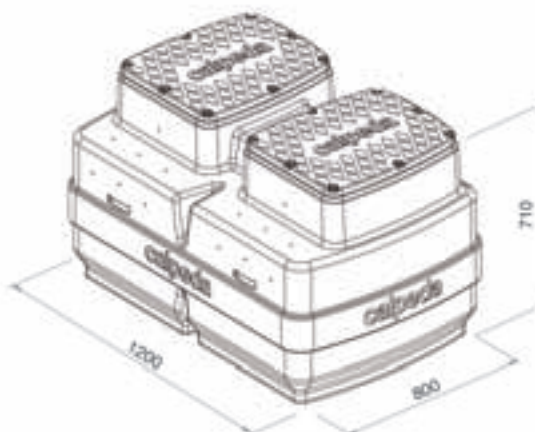

GMC, GMV

Submersible sewage and drainage pumps.

GMC, with single-channel impeller.

GMV, with free-flow (vortex) impeller.

2-pole induction motor, 50Hz (n = 2900 rpm)

GMV, GMC: three-phase 400 V;

with 2 built-in thermal protectors to be connected to the control panel.

GMVM, GMVM: single-phase 230 V ± 10%, built-in thermal protector and built-in capacitor (without float switch)

Cable length 10 m.

Liquid temperature up to 35 °C.

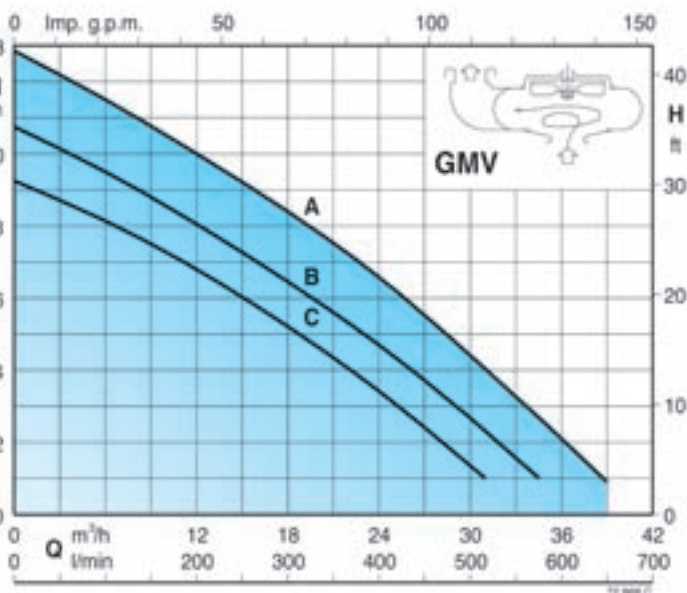
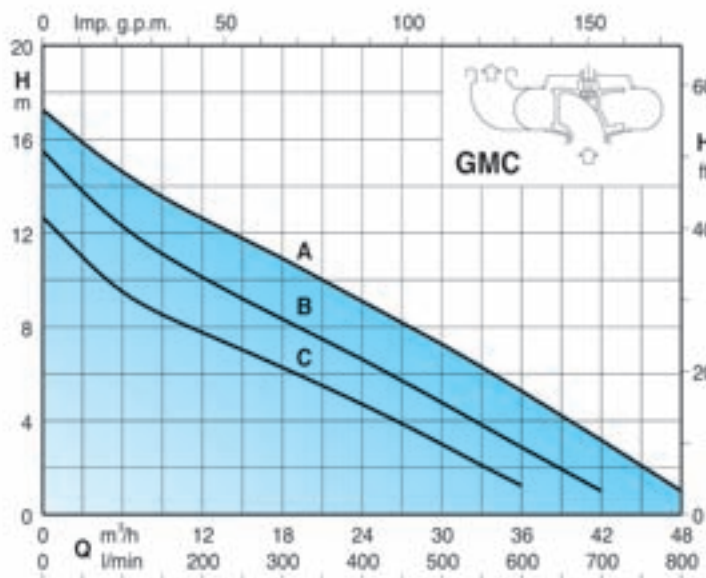

Pumps characteristics



GEO 500-2GM..

Features

Automatic waste water collecting and lifting station GMV, GMC series.

include:

- 1 tank capacity 500 lt
- 2 pumps - single-phase 10 m cable without float switch
- three-phase with 10 cable
- 1 support kit with 2 float switch
- 1 control box for three-phase version
- 2 duck foot coupling kit
- 2 discharge pipe kit Ø 63 mm in PVC with a ball valve and non-return ball valve

ON DEMAND

- 1 safety float switch and auto-supplied control panel for remote alarm with horn and flashing light
- extension 300 mm

Single-phase type	1 ~ 230 V		Q max m ³ /h	H max m
	kW	A		
GEO 500-2GMCM 50-65C	0,75x2	4,5x2	36x2	9,5
GEO 500-2GMCM 50-65B	1,1x2	6,5x2	42x2	12,5
GEO 500-2GMVM 50-65C	0,75x2	4,5x2	31x2	8
GEO 500-2GMVM 50-65B	1,1x2	6,5x2	35x2	9,5

Three-phase type	3 ~ 400 V		Q max m ³ /h	H max m
	kW	A		
GEO 500-2GMC 50-65C	0,75x2	1,9x2	36x2	9,5
GEO 500-2GMC 50-65B	1,1x2	2,7x2	42x2	12,5
GEO 500-2GMC 50-65A	1,5x2	3,8x2	48x2	14,5
GEO 500-2GMV 50-65C	0,75x2	1,9x2	31x2	8
GEO 500-2GMV 50-65B	1,1x2	2,7x2	35x2	9,5
GEO 500-2GMV 50-65A	1,5x2	3,8x2	39x2	11,5

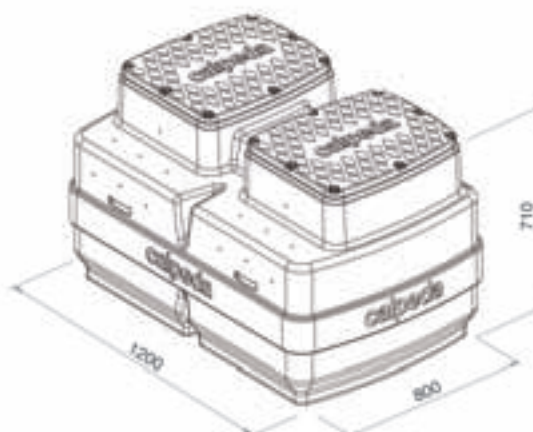

GMC, GMV

Submersible sewage and drainage pumps.

GMC, with single-channel impeller.

GMV, with free-flow (vortex) impeller.

2-pole induction motor, 50Hz (n = 2900 rpm)

GMV, GMC: three-phase 400 V;

with 2 built-in thermal protectors to be connected to the control panel.

GMVM, GMVM: single-phase 230 V ± 10%, built-in thermal protector and built-in capacitor. (without float switch)

Cable length 10 m.

Liquid temperature up to 35 °C.

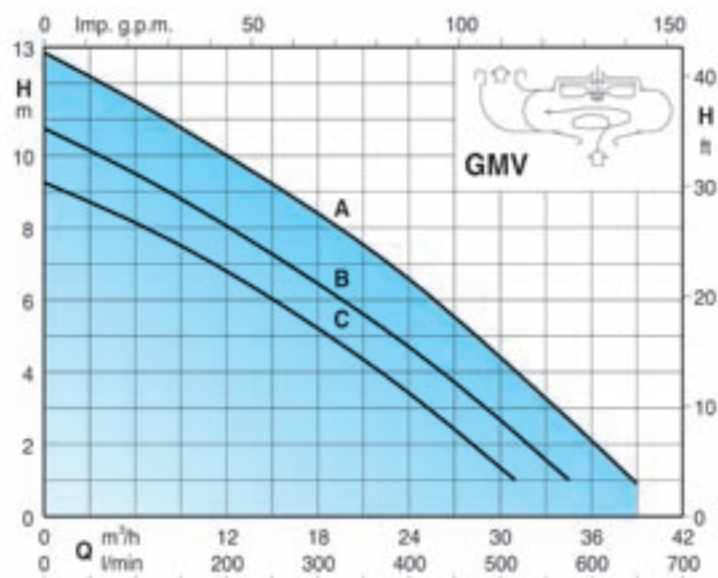
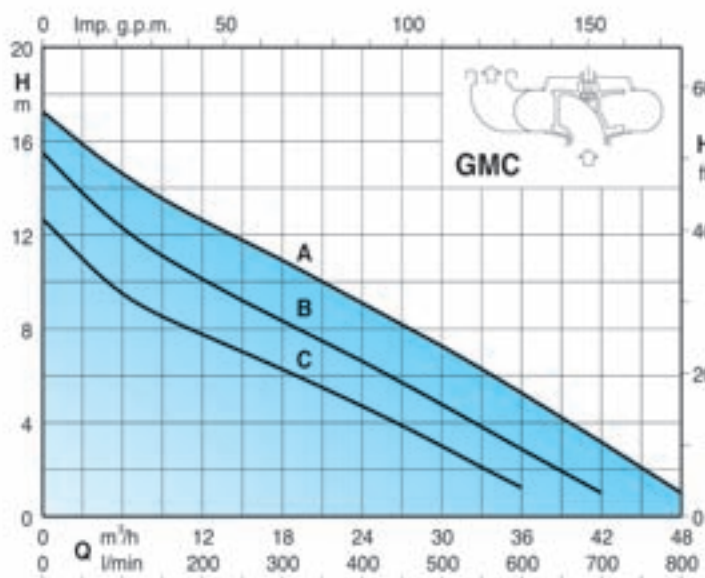

Dimensions and weights

GEO 40

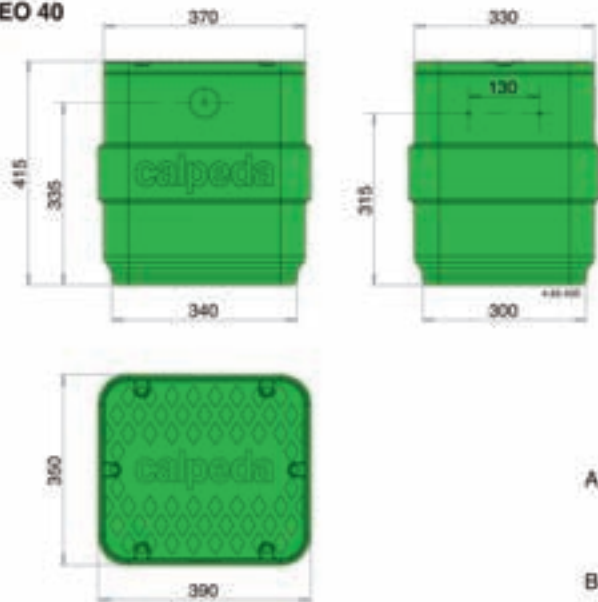

Tank
kg.6

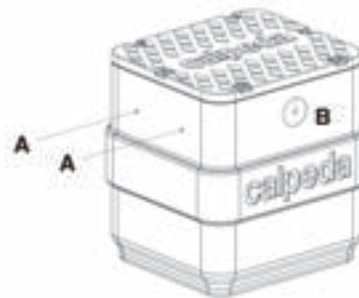

- A) Arrangement for :
 Ø 40 mm inlet
 Ø 40 mm outlet
 Ø 25 mm relief
- B) Cable passage with Shuko plug



GEO 230

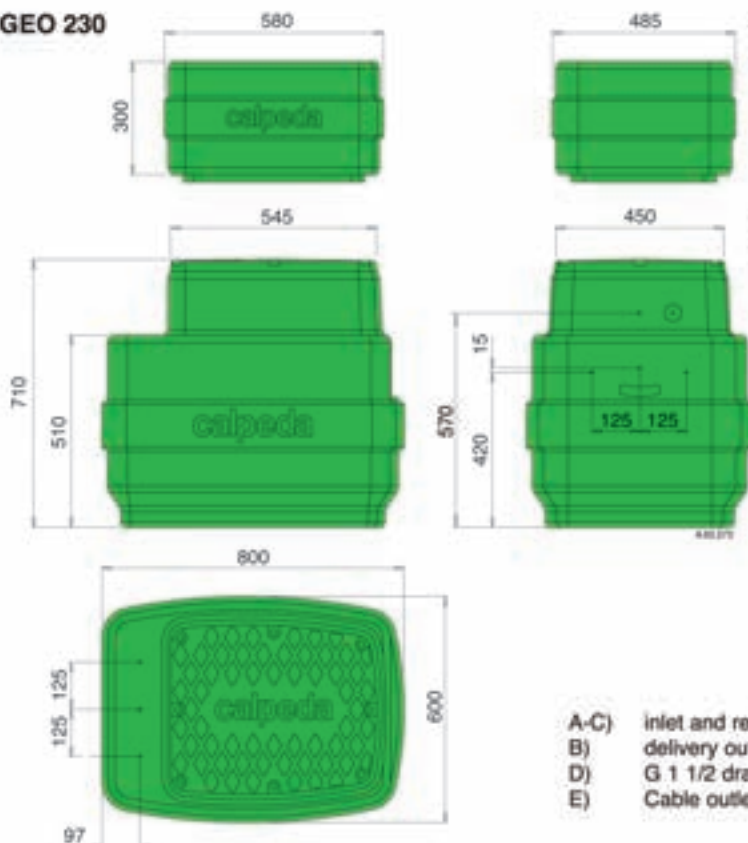

Extension
kg.4,5

Tank
kg.16

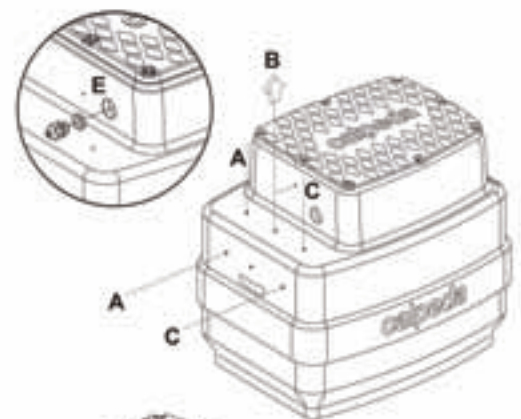

- A-C) inlet and relief
 delivery outlet
- B) G 1/2 draining outlet
- E) Cable outlet

Dimensions and weights

GEO 500

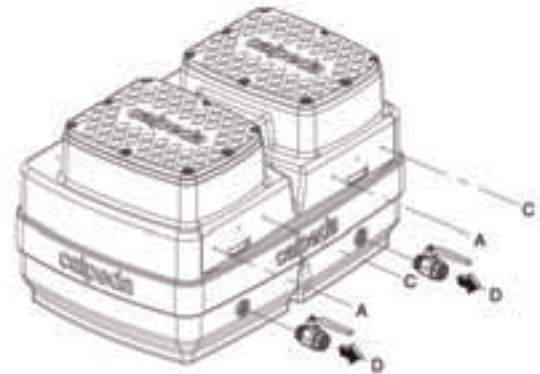
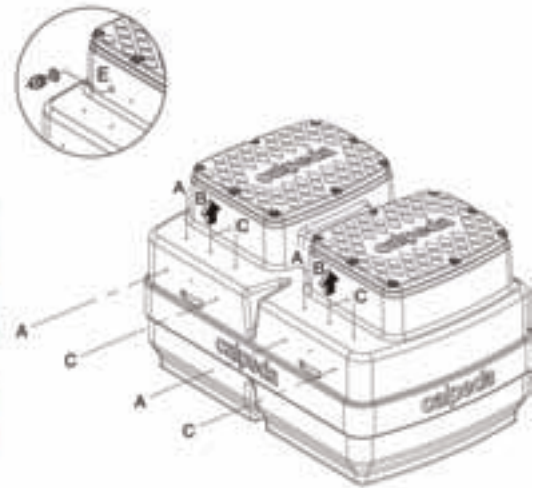
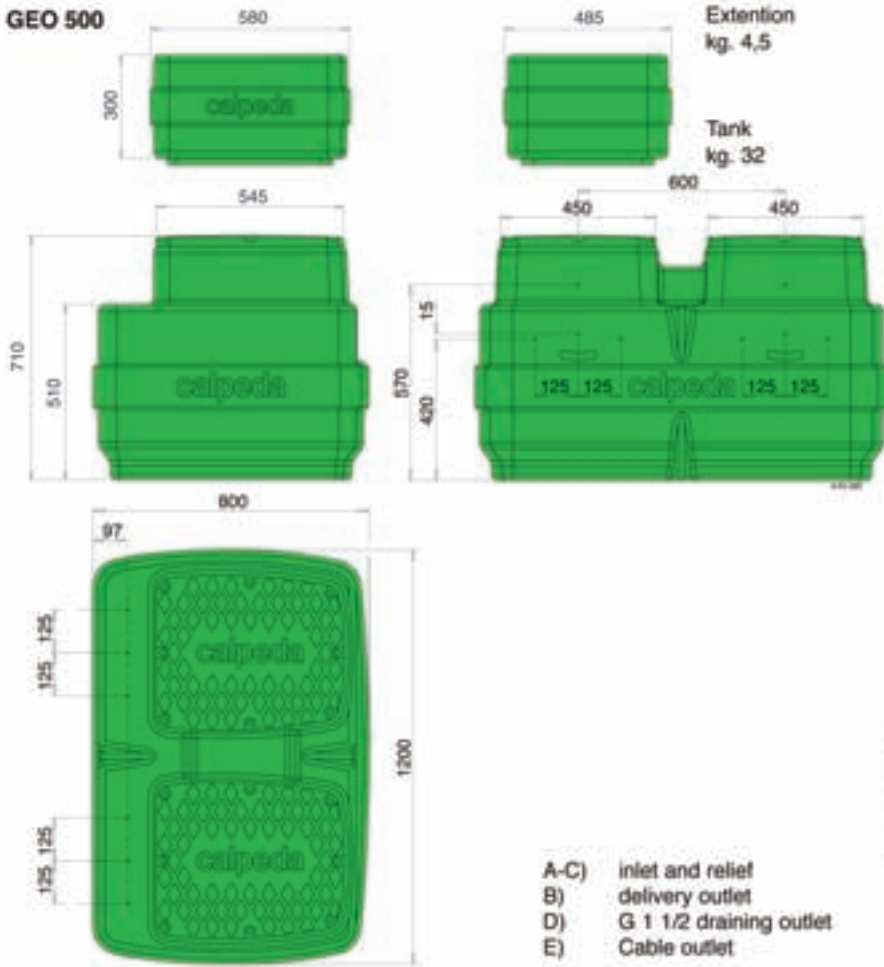

- A-C) inlet and relief
- B) delivery outlet
- D) G 1 1/2 draining outlet
- E) Cable outlet

Installation examples



LIFTING STATION SIZING

Normally the domestic waste water flows by gravity into the mains sewage collectors.

If there are underground rooms with discharge positions below the sewage main, a lifting station with one or more pumps may be required.

It is necessary to remember that the UNI-EN 12056-4 standard allows rainwater to be pumped to the sewage main only in exceptional cases.

To sizing a lifting station pump it is necessary to calculate the flow Q_{tot} and the Head h_{mt} necessary for the water drainage.

FLOW CALCULATION

The flow of the lifting pumps can be calculated using Table 1, according to the number of people using the building and the location of the building. It is easy to calculate the flow Q_r of the sewage water.

The Q_r value is already adjusted by a coefficient that includes the peak hours, when the water consumption is higher.

The lifting systems of waste water are usually separated from the rainwater system. In case of a mixed system is required to sum the flow Q_m of the rainwater of the Table 2 with the flow Q_r of the Table 1.

The table indicates the rainwater flow Q_m as a function of the exposed surface to rainfall, it varies according to the capacity of the surface to absorb rain water (Table 3).

The total flow of the pump or pumps is:

$$Q_{tot} = Q_r + Q_m$$

HEAD CALCULATION

To calculate the head h_{mt} it is necessary to add the geodetic head existing between the fluid levels with the head losses from internal friction created by the flow of the fluid in the hydraulic pipes and fittings (Figure 1).

After the choice of the discharge pipe diameter, such that the flow speed it is not lower than 0,7 m/s (to avoid deposits) and higher than 2,3 m/s, it is possible to determine the distributed head loss H_d and concentrated head loss H_v H_c , due to valves and curves (Table 4).

The sum of the head losses ΔP_c is:

$$\Delta P_c = H_d + \sum H_v + \sum H_c$$

The total head h_{mt} is calculated as:

$$H_{mt} = H_g + \Delta P_c$$

- 1) Water arriving from sinks discharge, toilets, showers, washing machines etc.
- 2) Excluding consumption from industrial processes.
- 3) The unit flow reference is 1,5 l/min/m²

Table 1

Maximum flow of domestic waste water at peak demand

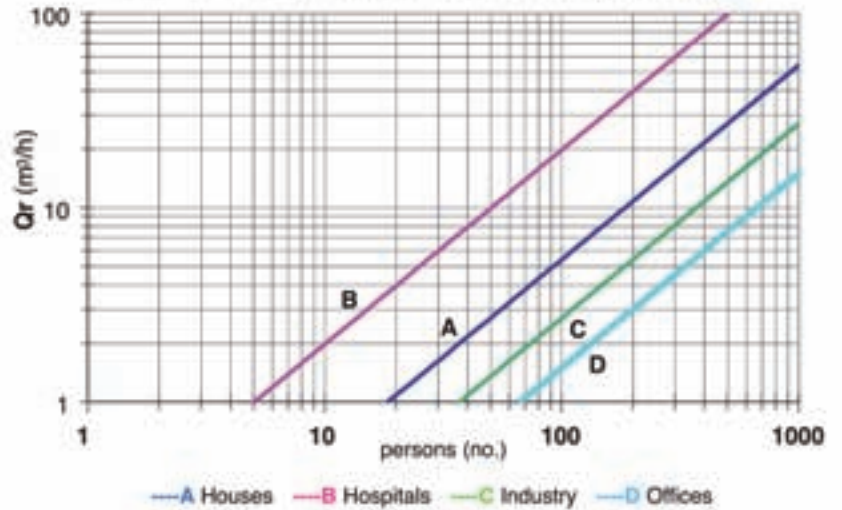

Table 2
Rainwater Flow

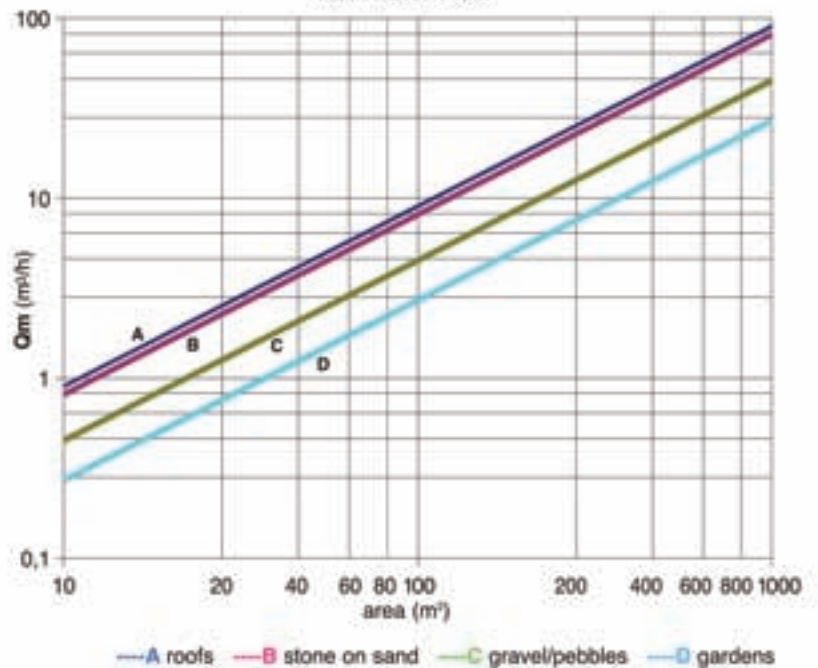

Figure 1

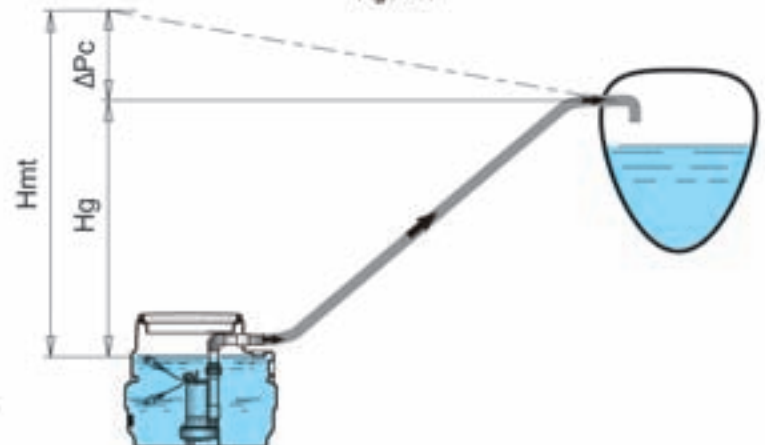

Table no. 3
Head loss in m for PVC PN6 (m) pipes

PVC pipe PN6 D _e mm	Q m ³ /h Q l/min	1,8	3,6	5,4	7,2	9	18	27	36	50,4	64,8	90	126	162	180
		30	60	90	120	150	300	450	600	840	1080	1500	2100	2700	3000
50		0,24	0,85	1,8	3,1	4,6	16,7	35,3	-	-	-	-	-	-	-
	HL	0,30	0,99	2,26	3,98	5,49	20,9	44,4	-	-	-	-	-	-	-
63		0,08	0,26	0,56	0,95	1,11	5,2	10,9	18,6	34,8	-	-	-	-	-
	V	0,18	0,37	0,55	0,73	0,92	3,83	7,75	10,6	15,13	-	-	-	-	-
75		0,11	0,24	0,4	0,61	0,72	2,2	4,6	7,9	14,7	23,4	43	-	-	-
	m/100m	0,26	0,59	0,91	1,24	1,49	4,79	9,93	16,7	31,8	49,3	94,2	-	-	-
90		0,05	0,1	0,16	0,25	0,3	0,9	1,9	3,3	6,1	9,7	17,8	33,2	-	-
	m/s	0,18	0,27	0,36	0,45	0,54	1,64	3,34	5,79	10,6	16,2	30,7	57,6	-	-
110		0,04	0,06	0,09	0,3	0,67	1,15	2,15	3,4	6,25	11,7	18,5	22,5	-	-
		0,17	0,2	0,29	0,46	0,58	1,81	3,4	6,25	11,7	18,5	22,5	-	-	-
125		0,03	0,05	0,07	0,17	0,36	0,6	1,15	1,84	3,37	6,3	10	12,2	-	-
		0,18	0,23	0,29	0,45	0,58	1,81	3,4	6,25	11,7	18,5	22,5	-	-	-
140		0,03	0,1	0,2	0,35	0,65	1,05	1,95	3,6	5,77	7	-	-	-	-
		0,36	0,54	0,72	1,01	1,35	4,0	7,7	11,4	17,1	24,8	37,5	47,2	-	-
160		0,05	0,11	0,18	0,34	0,55	1,02	1,9	3	3,66	-	-	-	-	-
		0,28	0,41	0,55	0,77	0,99	2,99	5,38	7,9	11,8	17,1	24,8	37,5	-	-
180		0,03	0,06	0,1	0,19	0,31	0,57	1,06	1,69	2,05	-	-	-	-	-
		0,22	0,33	0,43	0,61	0,79	2,39	4,38	6,37	9,36	13,3	19,2	27,1	-	-
200		0,02	0,04	0,06	0,12	0,18	0,34	0,64	1	1,23	-	-	-	-	-
		0,18	0,26	0,35	0,49	0,63	1,93	3,52	5,11	7,7	11,3	16,9	24,5	-	-
225		0,02	0,04	0,07	0,1	0,19	0,36	0,57	0,7	-	-	-	-	-	-
		0,21	0,29	0,39	0,53	0,7	2,1	3,8	5,5	8,2	11,9	17,6	25,3	-	-
250		0,02	0,04	0,06	0,12	0,22	0,34	0,42	-	-	-	-	-	-	-
		0,23	0,32	0,41	0,56	0,73	2,2	3,9	5,6	8,3	12,0	17,7	25,4	-	-
280		0,01	0,02	0,04	0,07	0,13	0,2	0,24	-	-	-	-	-	-	-
		0,18	0,25	0,32	0,45	0,59	1,8	3,2	4,6	6,9	10,3	14,7	21,1	-	-

Table no. 4
Head loss in cm for bends and gate valves

Water flow velocity m/sec	$\alpha = 90^\circ$ sweep elbow					Gate valves
	$\frac{d}{R} = 0,4$	$\frac{d}{R} = 0,6$	$\frac{d}{R} = 0,8$	$\frac{d}{R} = 1$	$\frac{d}{R} = 1,5$	
0,4	0,11	0,13	0,16	0,23	0,43	0,23
0,5	0,18	0,21	0,26	0,37	0,67	0,37
0,6	0,25	0,29	0,36	0,52	0,97	0,52
0,7	0,34	0,40	0,48	0,70	1,35	0,70
0,8	0,45	0,53	0,64	0,93	1,7	0,95
0,9	0,57	0,67	0,82	1,18	2,2	1,20
1,0	0,7	0,82	1,0	1,45	2,7	1,45
1,5	1,6	1,9	2,3	3,3	6	3,3
2,0	2,8	3,3	4,0	5,8	11	5,8
2,5	4,4	5,2	6,3	9,1	17	9,1
3,0	6,3	7,4	9	13	25	13
3,5	8,5	10	12	18	33	18
4,0	11	13	16	23	42	23
4,5	14	17	21	30	55	30
5,0	18	22	27	38	72	38

EXAMPLE OF CALCULATION

Suppose it is required to size a lifting station, for a residential building where 80 people live. The pumps will have to lift waste water up to an additional tank located 5m higher, the linear distance between the 2 tanks is 70 m. In addition the station will receive rainwater from 400 m² of tarmac, roof surfaces and 120 m² of garden.

Considering: $Q_{tot} = Q_r + Q_m$

It is possible to calculate the Q_r from the Table1 which is 4 m³/h, while Q_m is obtained from the Table 2 and is 36 m³/h (roofs and tarmac) plus 2 m³/h from gardens, with this value Q_{tot} is 42 m³/h. At this flow it will be necessary split the flow between two pumps.

We choose a delivery pipe diameter such that the flow rate with two pumps in operation does not exceed 2,3 m / sec and not be lower than 0,7 m / s with a single pump.

From (Table 3) we obtain:

42 m³/h \Rightarrow 1,4 m/s \Rightarrow TUBO DN 110 (with two pumps in parallel operation)

21 m³/h \Rightarrow 0,7 m/s \Rightarrow TUBO DN 110 (with one operating pump)

The distributed head loss in 70 m pipe with 720 l / min is 1,13 m (Table 3), then from the formula:

$$H_{mt} = H_g + \Delta p_c$$

It is obtained $H_{mt} = 6,13$ mca

he suitable pumps are no. 2 GMCM 50-65B and then it result a station type GEO 500-2GMCM 50-65B.

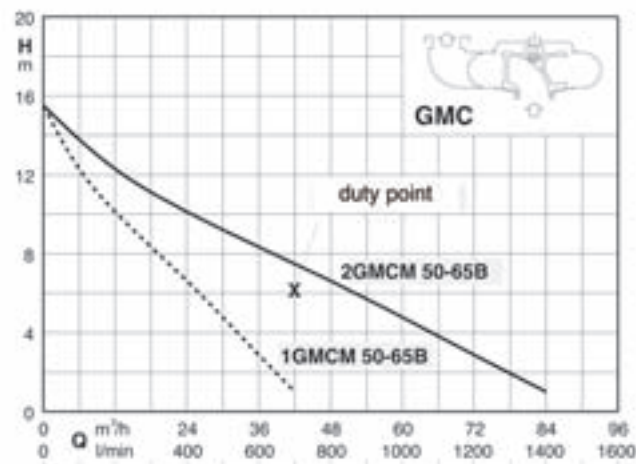

INSTALLATION EXAMPLE



Lifting
Stations



- **GEOMINI** Sanitary evacuator
- **GEOBOX** Lifting stations for domestic applications

 **calpeda**[®]

CE

New sanitary evacuator

- More attractive and discreet, thanks to its innovative compact design, small size, silent operation and odour-free ventilation system with active carbon filter system.
- More versatile since a single model serves for a large variety of places that are hard to reach and in locations that pose technical problems.
- More hygienic to repair and maintain, as its innovative removable pump system performs maintenance without the need to dismantle the pipes, and makes it unnecessary to come into contact with foul water.
- More features since it can be connected to multiple appliances: toilets, washbasins, showers, bathrooms, bidets, dishwashers, washing machines and sinks
- More powerful and efficient, with the special high-output pump that drives the foul water up to 6 metres vertically and up to 65 metres horizontally.

Technical features

- Direct toilet connection: DN 100.
- Funnel in accordance with EN 33 and EN 37 standards.
- Diameter of foul water inlets: DN 40 or 32
- Main non-return valve and flaps in the foul water inlets
- Ventilation outlet with filter and safety valve
- Discharge pipe for DN 25 or 32 outlets. Adjustable.
- Non-return valve in the tank output pipe
- Based on the EN 12050-3 standard.
- Protection class: IP 44

Compact, discreet and adaptable

- Modern, compact and symmetrical design to minimise the visual presence of the equipment in the installation.
- Its size enables it to be installed with any WC model available on the market, and its design enables unused foul water inlets to be concealed.
- Extremely practical: makes it unnecessary to install pipes for the evacuation of odours.

Difficult locations:

- Locations that are lower than the sewer system level: garages, basements, stairwells, bedrooms...
- Locations that are on the sewer system level, with horizontal separation: swimming pool changing rooms, garden huts...
- Facilities in sites not intended for this purpose: attics, stairwells, bedrooms, offices, hotels, factories, restaurants, bars, gyms, stores, old buildings, second homes...
- Layouts without drainage connections.
- Facilities intended to minimise the impact of installation work.

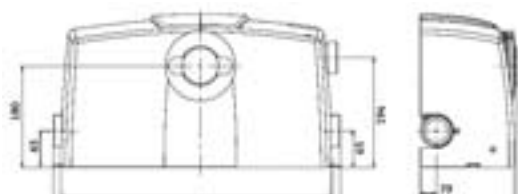
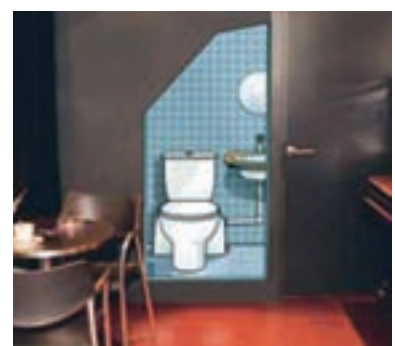
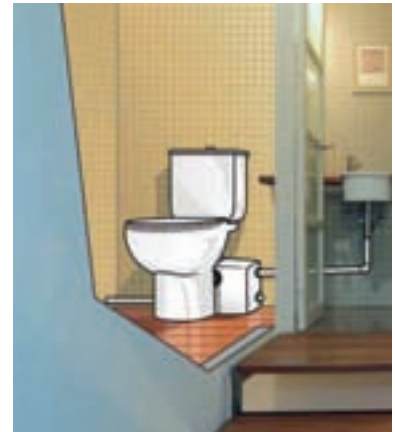
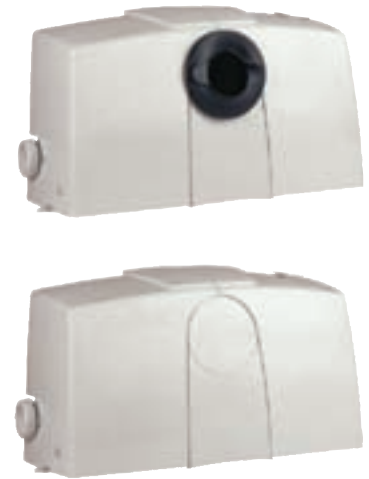

502 x 170 x 265 mm. Weight: 8 Kg.

Lifting stations for domestic applications

Applications:

Automatic stations to lift and evacuate wastewater for domestic application, detached homes, cottages, rural properties, second homes, restaurants, stores, workshops, etc.
GEOBOX collects, stores and delivers waste water to the sewerage manifold with easy installation and high efficiency.

Materials

300 l capacity tank (240 l of useful volume) manufactured in 6 mm thick high-density polyethylene, with special bottom configuration to avoid sediments.
Fittings in PVC and gaskets in EPDM.
Water level controlled by float switches.

Motor

For flow rates, manometric head and electric motor parameters, check the pump's data table.

Equipment

All sets are supplied with control panel.
Supplied with 10 m power cord.

Limitations

Maximum temperature of liquid: 40 °C.

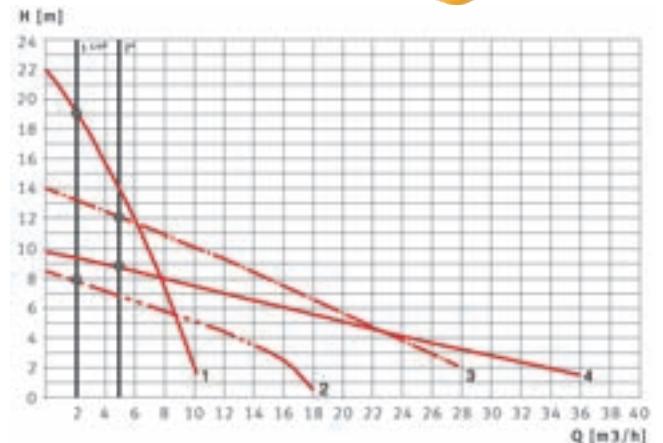

Model	A	B	C
GEOBOX 300	770	760	615
GEOBOX 600	1230	760	615

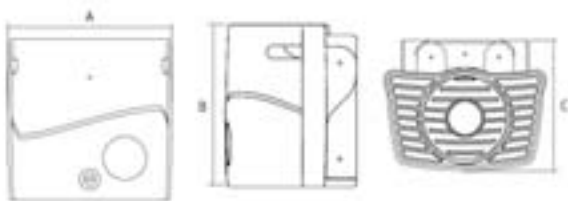

GEOBOX 300
1 pump
1 240 litre tank
1 packaging kit
1 control panel

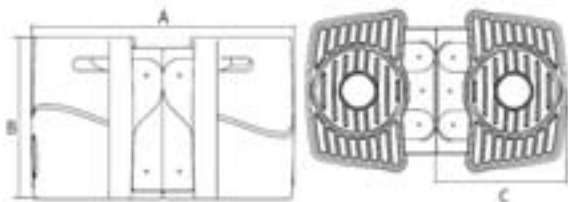

GEOBOX 600
2 pumps
2 240 litre tanks
1 packaging kit
1 control panel

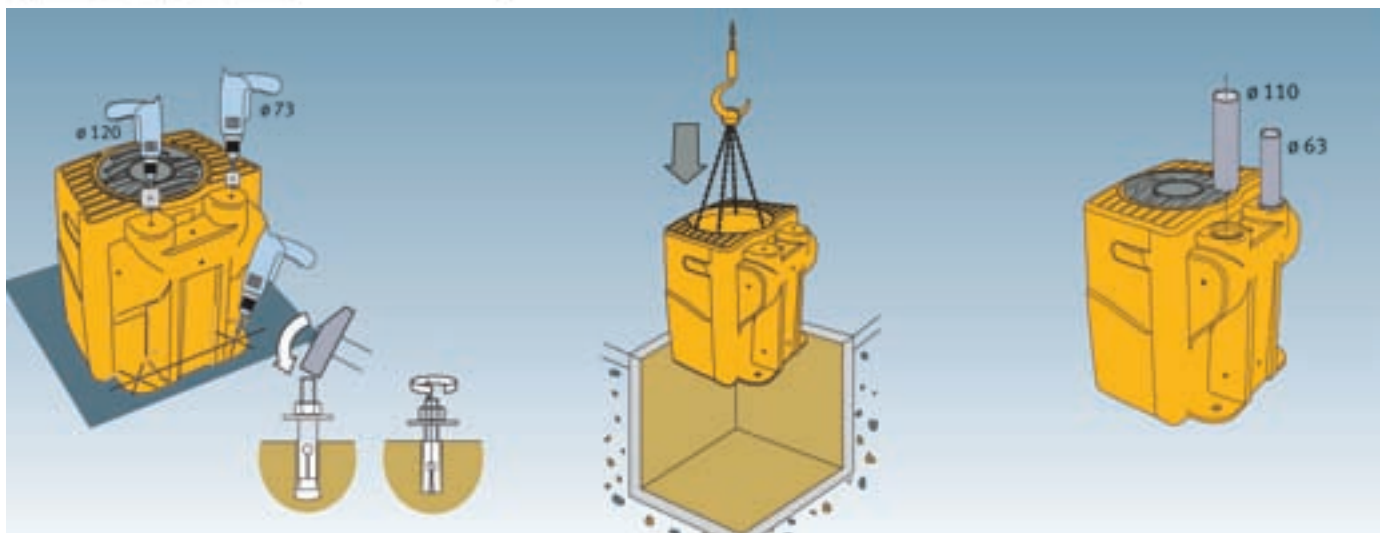



CALPEDA SPA

Via Roggia di Mezzo, 39 - 36050 Montorso Vicentino - Vicenza - Italy
Tel: + 39-0444 476 476 - **Fax:** + 39-0444 476 477 **e-mail:** info@calpeda.it

www.calpeda.com